



**HIGHLEAD**

**GC24698-5R/-5L/-6**

**Post-bed heavy duty compound feed  
lockstitch sewing machine (20)**

**Instruction Manual  
Parts Catalog**

**SHANGHAI HUIGONG NO.3 SEWING MACHINE FACTORY**

---

----- CONTENTS -----

1.OPERATING INSTRUCTION .....	1
2.SETTING UP THE MACHINE .....	1
3.CAUTION BEFORE STARTING THE OPERATION.....	1
4.OILING.....	2
5.NEEDLE .....	2
6.THREAD.....	3
7.WINDING THE LOWER THREAD ON THE BOBBIN.....	3
8.THREADING THE NEEDLE.....	3
9.REGULATING THE THREAD TENSIONS.....	4
10. ADJUSTMENT OF THE STITCH LENGTH.....	4
11. ADJUSTMENT OF THE PRESSURE.....	5
12.REVERSE STITCHING.....	5
13.RELATIVE POSITION OF VIBRATING AND LIFTING PRESSER BAR, ALSO, OF THE NEEDLE AND THE NEEDLE HOLE OF THE FEEDER.....	6
14. ADJUSTMENT THE HEIGHT OF THE FEED DOG .....	6
15. TIMING BETWEEN THE HOOK AND THE NEEDLE.....	6
16.ADJUSTMENT OF BOBBIN CASE OPENER .....	7
17.ADJUSTMENT OF THE HEIGHT OF THE PRESSER FEET .....	8
18.TIMING OF THE VIBRATING AND LIFTING PRESSER FEET .....	8
19.ADJUSTMENT OF THE CLEARANCE FOR THE VIBRATING AND LIFTING PRESSER FEET....	9
20.ADJUSTMENT OF THE THREAD CONTROLLER SPRING.....	10
21.REPLACEMENT OF THE CONNECTION BELT.....	10
22.TO RE-ENGAGE THE SAFETY CLUTCH.....	11
<b>PARTS CATALOG</b>	
A.ARM BED AND IT'S ACCESSORIES.....	12
B.ARM SHAFT MECHANISM.....	14
C.PRESSER FOOT MECHANISM.....	17
D.STITCH REGULATOR AND FEED ROCKING MECHANISM.....	20
E.HOOK SADDLE MECHANISM(GC24698-6).....	23
F.HOOK SADDLE MECHANISM(GC24698-5L).....	26
G.HOOK SADDLE MECHANISM(GC24698-5R).....	29
H.THREAD TENSION REGULATOR MECHANISM .....	32
I.SPECIAL PARTS FOR GC24698-5L/5R.....	35
J.SPECIAL PARTS FOR GC24698-6 .....	37
K.ACCESSORIES.....	38

---

## 1. OPERATING INSTRUCTIONS HIGHLEAD GC24698-5L、GC24698-5R、GC24698-6 SERIES MODEL

This is a guide to use of HIGHLEAD GC24698-5L、GC24698-5R、GC24698-6 series model long-arm high speed for heavy-duty materials sewing machine with compound feed and walking foot feeding mechanism, under the best condition.

**Please read this guide thoroughly so that you may expect good performance.**

### Specifications

	SINGLE NEEDLE GC24698-5L/5R	TWO NEEDLE GC24698-6
MAX. SPEED (s. p. m.)	1, 200	
MAX. STITCH (mm)	10	
PRESSER FOOT CLEARANCE	Hand Lifter (mm)	20
	Pedal lifter (mm)	28
NEEDLE	DY × 3 (standard No. 24~26)	
BOBBIN SIZE (mm)	Φ 37 × 13	
WORKING SPACE (mm)	508 × 153	
BED DIMENSION	846 × 230	
POWER REQUIRED (W)	750W SERVO MOTOR	
MOTOR PULLEY DIA. (mm)	Φ 70 / Φ 60 (50 / 60Hz)	Φ 70 / Φ 60 (50 / 60Hz)

### USE FOR

Tent, Sailcloth, Rubberized, Fabrics, Heavy Synthetic, Heavy Upholstery Materials, Fiber Plate, Leather, Etc.

## 2. SETTING UP THE MACHINE (Fig. 1)

Setting up the machine on the table after removed two pieces of supporting bolts (A) under the bed.

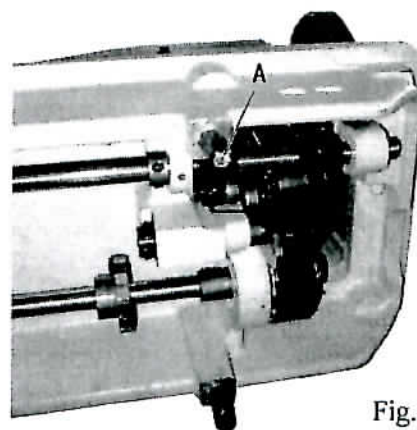

Fig.1

## 3. CAUTION BEFORE STARTING THE OPERATION

- 1) Do not operate the machine, even if only for testing and or idling, unless it has been properly oiled at every spot and reservoir required lubrication.

During practice period the new machine should be oiled more frequency.

- 2) The machine pulley turns toward to the operator.
- 3) Do not operate the machine at maximum speed of 1,200 s.p.m., for starting operation. To take practice operation at speed of 700 s.p.m., but operating speed are to be changed to proper conditionsuitable for the materials in case by case.



#### 4.OILING (Figs. 2、 3、 4、 5&6)

1) Oil should be applied at each of the place designated by arrows in Figs. 2、 3、 4、 5&6

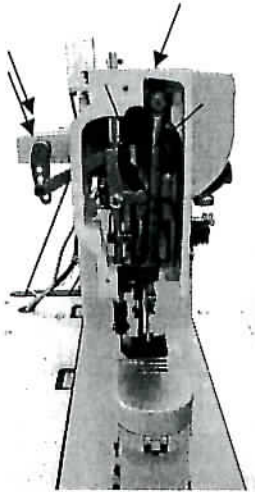

Fig.2

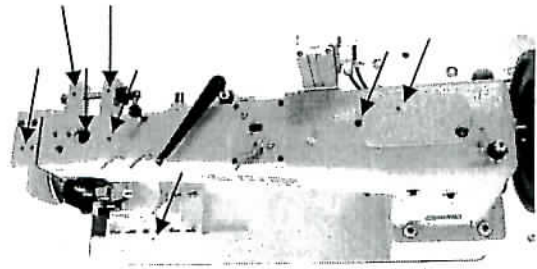

Fig.3

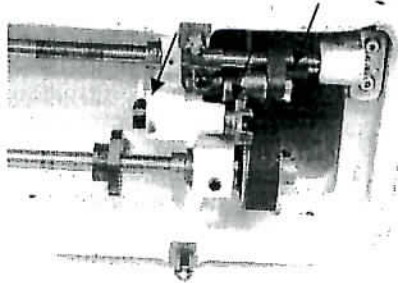

Fig.4

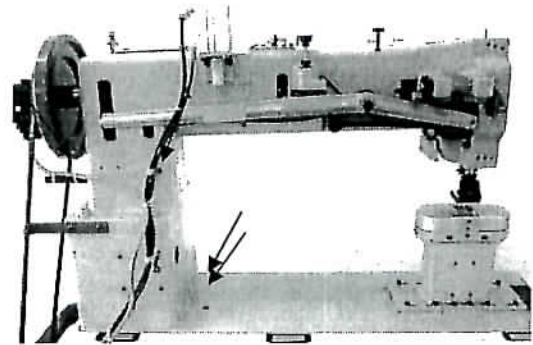

Fig.5

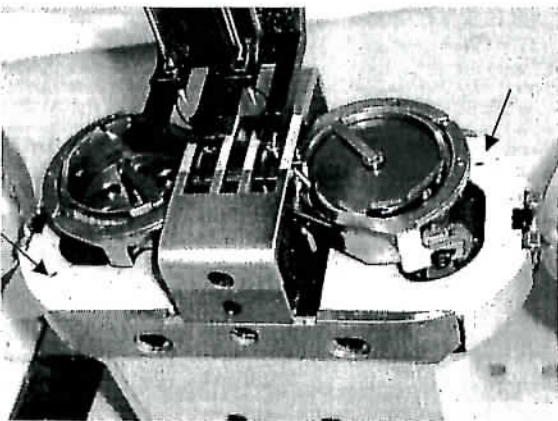

Fig.6

2) When in continuous use, it should be oiled at least twice a day.

#### 5.NEEDLE (Figs. 7)

1) HIGHLEAD GC24698-5L、 GC24698-5R、 GC24698-6 series machines are set up to use standard needle of DY×3 (standard No. 24~26)

- 2) The size of needle to be used should be determined by the size of thread, type and thickness of the sewing materials.
- 3) To insert the needle, turn the machine pulley over toward you until the needle bar moves up to its highest point, put the needle up into the needle bar as deeply as it will go, with the long groove of the needle faced outside.
- 4) Tighten the needle set screw securely.

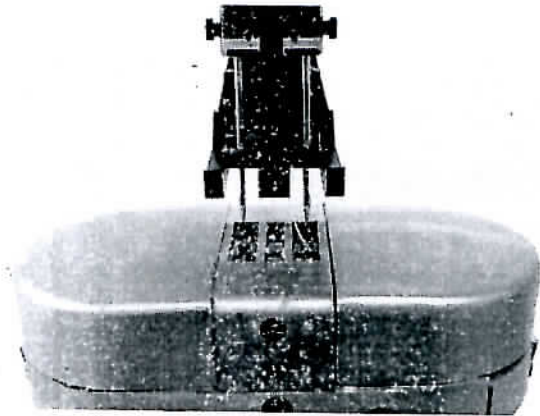

Fig.7

**6.THREAD (Fig. 8)**

Normally, left twisted thread is used for upper (needle) thread. (But, for left side needle of twin-needle machine, it can be finished in fine results with right twisted thread.)

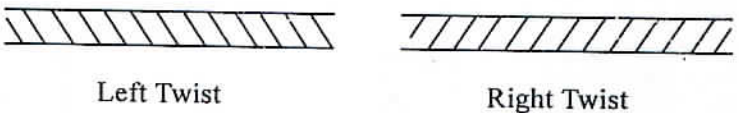

Fig.8

**7.WINDING THE LOWER THREAD ON THE BOBBIN (Figs. 9 & 10)**

- 1) Pass the thread through (1) - (3) , and wind several times around the bobbin (4) , which set up to the shaft of bobbin winder.
- 2) Press the lever (5) to arrow direction, then the bobbin winds the thread automatically, in engage with the operation of the machine.

The bobbin will automatically be stopped after the bobbin is filled with thread.

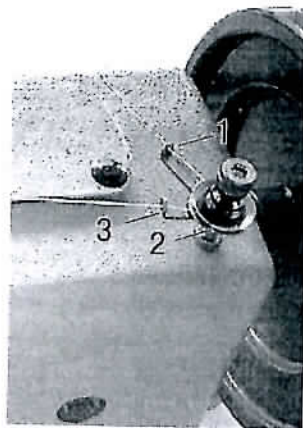

Fig.9

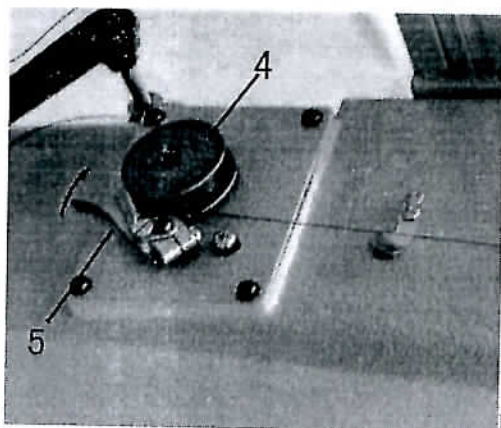

Fig.10

## 8.THREADING THE NEEDLE (Figs.11&12)

- 1) Pass the thread from thread guide (1) - eyelet (2) - tension disc (3) - tension thread guide (4) - guide (5) - thread take-up spring (6) - guide (7) - take-up lever (8) - guide (7) - lower guide (9) - self threading needle bar thread guide (10) - through the eye of the needle (11) .(Remark) Wind the thread a single time to tension thread guide (4) .
- 2) With the left hand hold the end of the needle thread leaving it slack from the hand to the needle. Turn the machine pulley over toward you until the needle moves down and up again to its highest point, thus catching the bobbin thread, draw up the needle thread, and the bobbin thread will come up with it through the hole in the feed dog. Lay the threads back under the presser feet and close the slide.

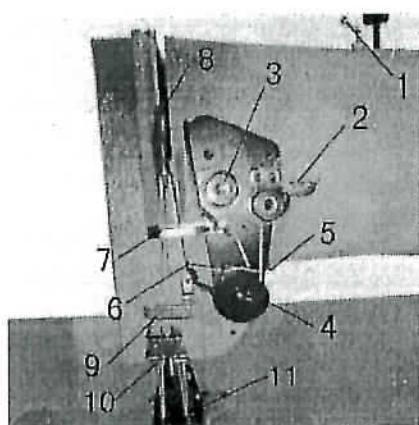

Fig.11

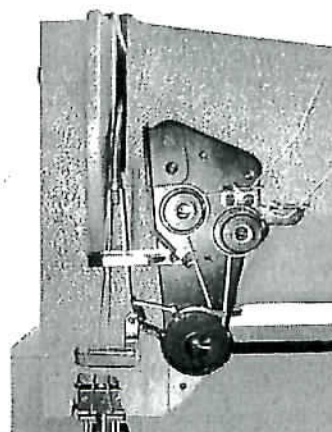

Fig.12

## 9.REGULATING THE THREAD TENSIONS (Figs. 13 & 14)

- 1) The tension on the needle thread is regulated by the thumb nut A (Fig. 13) .
- 2) The tension on the bobbin thread is regulated by the screw of the tension spring on the outside of the bobbin case B (Fig. 14) .

To increase the tension, turn over nut or screw to the right, and to decrease the tension, turn over nut or screw to the left.

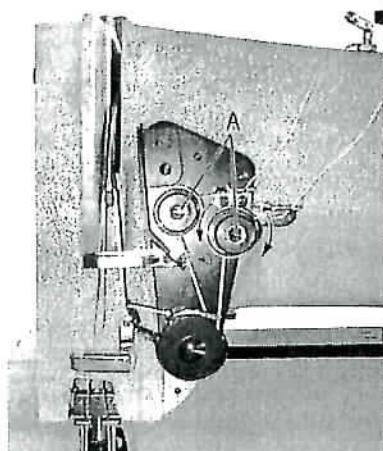

Fig.13

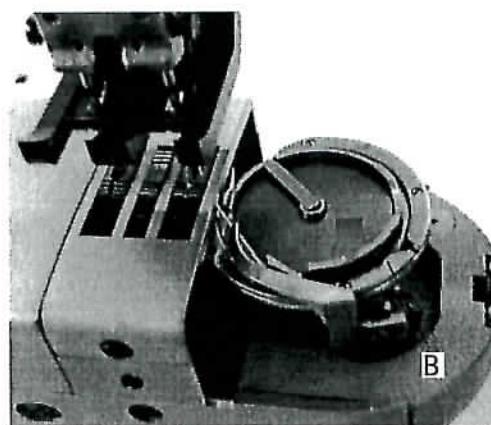

Fig.14



## 10. ADJUSTMENT OF THE STITCH LENGTH (Fig. 15)

The length of stitch is regulated by pressing down the button (1) with left hand, while turning the machine pulley (2) slowly with right hand in the condition of setting the top of button (1) to the feed eccentric.

To increase the length of stitch, turn the machine pulley over toward you. To decrease the length of stitch, turn the machine pulley to opposite direction.

When the desired length of stitch is obtained, operate the machine after fully confirmed releasing the button (1) to the original position.

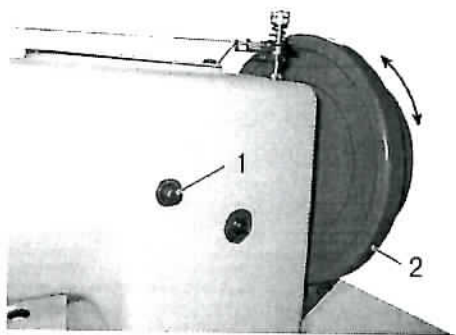

Fig.15

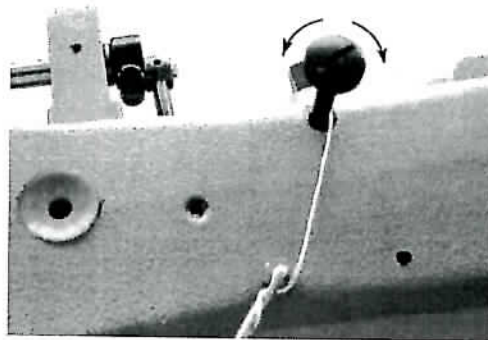

Fig.16

## 11. ADJUSTMENT OF THE PRESSURE (Fig. 16)

The pressure of the presser feet is regulated by the adjusting screw.

To increase the pressure, turn the screw to clockwise, and decrease it, turn the screw to counter-clockwise.

## 12. REVERSE STITCHING (Fig. 17)

To feed the work toward you, press the button A (Fig. 17)

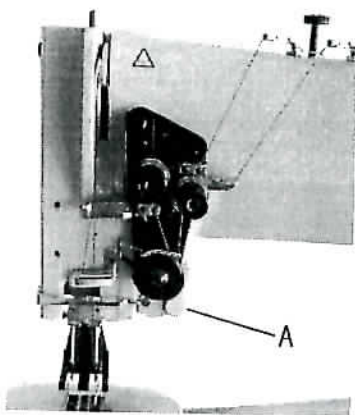

Fig.17

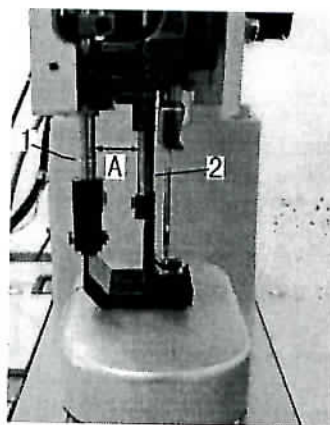

Fig.18

### 13. RELATIVE POSITION OF VIBRATING AND LIFTING PRESSER BAR, ALSO, OF THE NEEDLE AND THE NEEDLE HOLE OF THE FEEDER (Figs. 18 & 19)

- 1) The distance between the vibrating presser bar (1) and lifting presser bar (2), after adjusting the feed eccentric so that there is no feed movement of the needle bar, should be 15.5 mm (one needle) and 14.5 mm (two needle). To adjust by the screws for connecting crank (3).
- 2) Normally, relative position of the feed dog against the needle, the needle should be passed through the center of the needle hole of the feed dog. To adjust by the screw for the feed rock shaft bell crank (4).
- 3) Securely tighten the screws after finished adjustment.

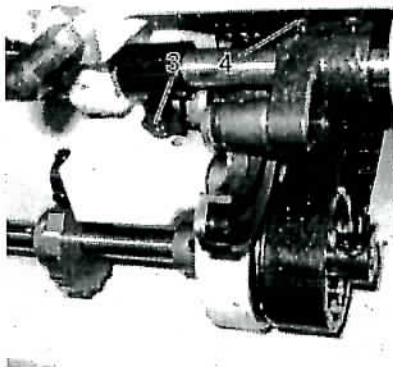

Fig.19

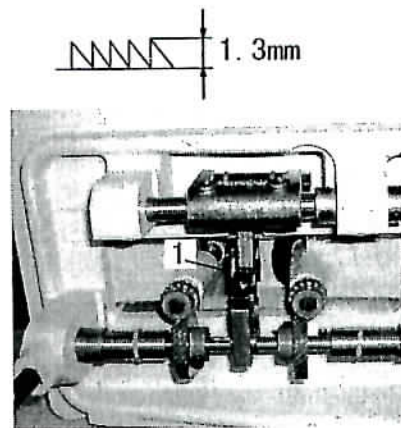

Fig.20

### 14. ADJUSTMENT THE HEIGHT OF THE FEED DOG (Figs. 20)

The maximum height of the feed dog from the surface of the needle plate is normally 1.3 mm.

To adjust this height by the screw on the feed lifting cam fork of the feed bar and raise or lower the feed dog, as may be required, and retighten the screw (1).

### 15. TIMING BETWEEN THE HOOK AND THE NEEDLE (Fig. 21, 22&23)

Set the feed eccentric with the button at no feeding position, and confirm the length between vibrating and lifting presser bar should be 15.5 mm.

- 1) Normal clearance between hook point and scarf of the needle is in 0.02 - 0.1 mm. (Fig.21).
  - (1) Loosen two screws (4) and (5) for hook saddle.
  - (2) Move hook saddle to right or left, as may be required, until hook point is as close to needle as possible without striking it.
  - (3) Then securely tighten two screws.
  - (4) To check the needle with careful attention free from bent before adjustment.
- 2) If the needle bar and sewing hook are correctly timed, the point of the hook will be at the center of the needle when the needle raised 3.8 mm + 0.5 mm from the lowest point. For the adjustment of timing, loosen



2 screws (1) for hook driving gear, and tap this gear to the right or left in clearance of 2 mm on the hook driving shaft until the point of the hook is at the center of the needle. Tapping to the right gives on earlier hook timing, and to the left gives later hook timing. Except the above case, to adjust in changing gear condition between hook driving gear (2) and hook shaft gear (3). Securely tighten the 2 set screws (1) for hook driving gear after finished adjustment. (Fig.22) .

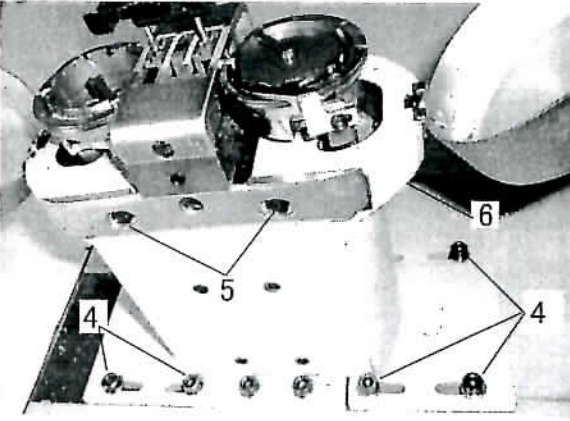

Fig.21

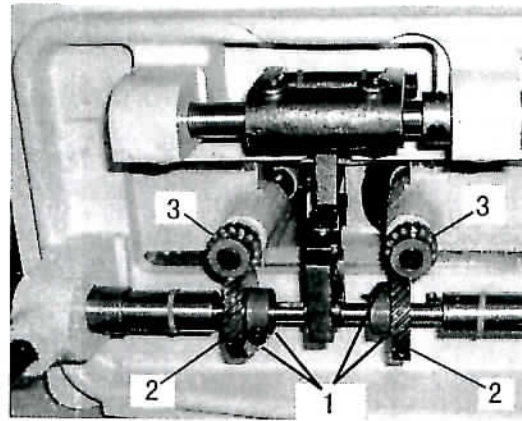

Fig.22

3) Height of the needle bar (Fig. 23) .

Normal clearance between top of the eye of the needle and hook point is 2.2 mm.

In case the needle bar is incorrectly set, loose the needle bar connecting stud pinch screw (A) and place the needle bar in correct position as required above, then retighten the screw (A) .

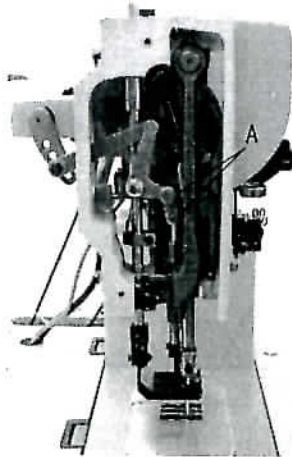
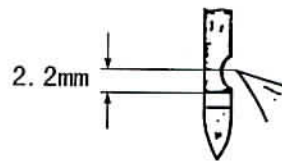

Fig. 23



**16. ADJUSTMENT OF BOBBIN CASE OPENER (Fig. 24)**

- 1) Turn the machine pulley until the top of the opener is located at the distance from the needle plate.
- 2) In this position, adjust it so that the clearance between the inside edge of the opener (A) and the top of the hook is about 0.3 - 0.8 mm.
- 3) Securely tighten the screw (B) after finished adjustment.

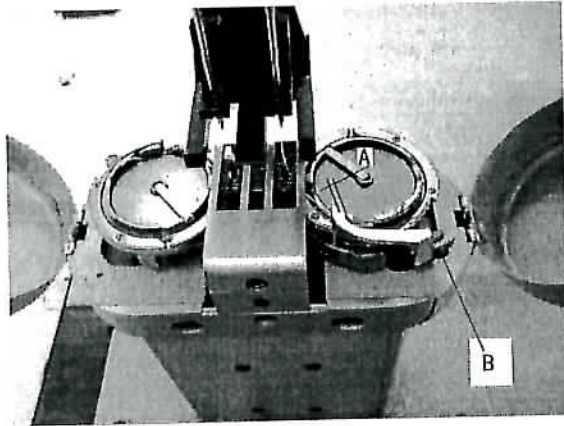

Fig.24

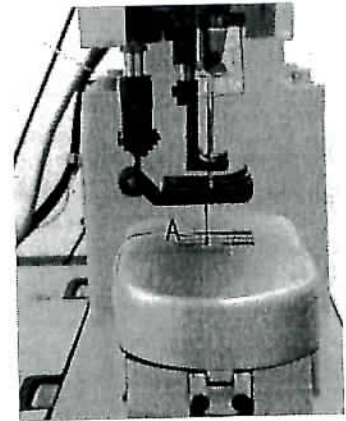

Fig.25

### 17. ADJUSTMENT OF THE HEIGHT OF THE PRESSER FEET (Figs. 25, 26 & 27)

Normal distance between the surface of the needle plate (A) and lifting presser foot at stopped position of the stop lever (C) is 19 mm.

When step on the lifting pedal, the lifting lever (B) will be at the stopped position, then pull the stop lever (C) to the stopped position.

- 1) To change the relative lift of the presser feet, loosen the screw (2) at the above condition.
- 2) The height of lift of the presser feet is adjusted by moving the screw of presser bar lifting bracket.
- 3) Normal distance between presser bar position guide bracket (3) and presser bar position guide (4) is 7 mm.

(Fig. 26)

Position of the lifting presser foot to shift in left and right is to be adjusted by the screw (2) for presser bar lifting bracket and the screw (5) for presser bar position guide bracket.

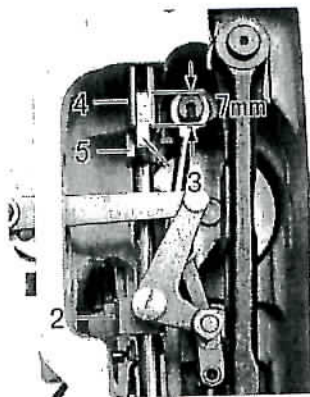

Fig.26

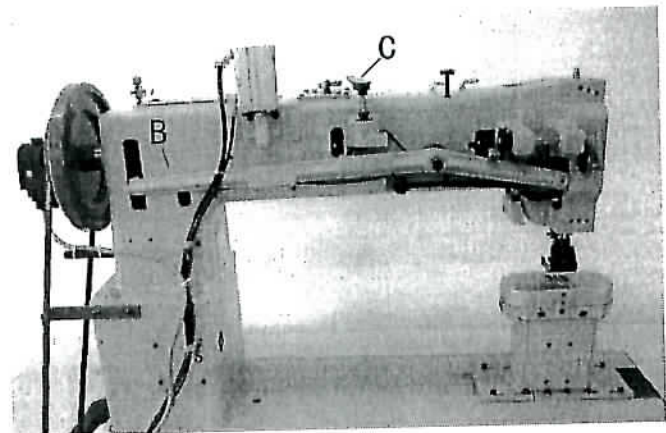

Fig.27

### 18. TIMING OF THE VIBRATING AND LIFTING PRESSER FEET (Fig. 28)

The amount of lift of the vibrating and lifting presser feet should be regulated according to the thickness of materials being sewn.

The feet should lift just enough to clear the materials.

As a rule, the vibrating and lifting presser feet should lift an equal height, but some grades of work may require



that they lift an unequal height.

To change the relative lift of the presser feet, loosen the screw (A) for lifting rock shaft crank and move the vibrating presser bar upward or downward as required, then securely tighten the screw (A).

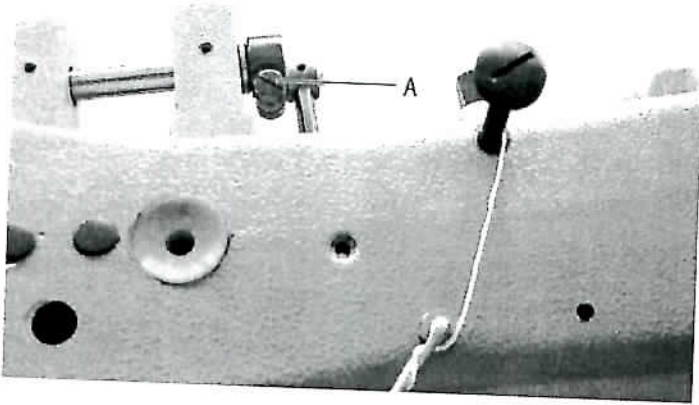
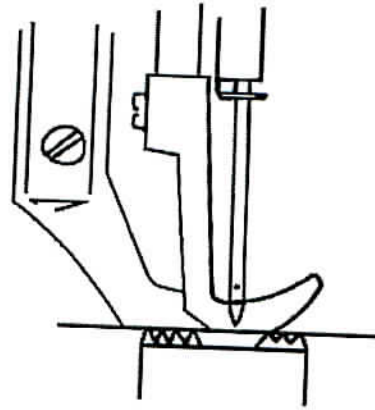

Fig.28



### 19. ADJUSTMENT OF THE CLEARANCE FOR THE VIBRATING AND LIFTING PRESSER FEET (Fig. 29) (RE-ADJUSTMENT THE TIMING OF THE VIBRATING AND LIFTING PRESSER FEET)

The amount of the lift of the alternating feed for the vibrating and lifting presser feet are to be adjusted by the lifting bell crank link screw stud (1).

To decrease the movement in setting the stud (1) at the upper position, and to increase the movement in setting the stud (1) at the lower position. After setting to the required position, securely tighten the stud (1) with nut (2).

The clearance for the vibrating and lifting presser feet are being adjusted at maximum, so that the clearance of them should be adjusted according to the materials being sewn.

The timing position for the vibrating and lifting presser feet should be regulated by Fig. 28&29.

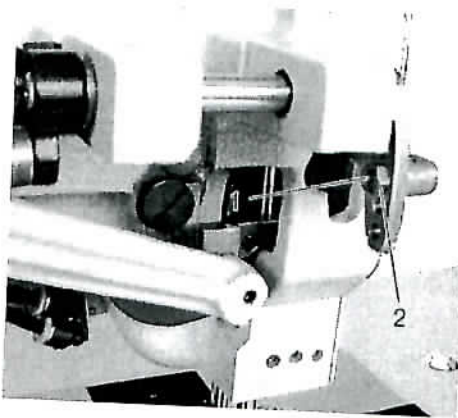

Fig.29

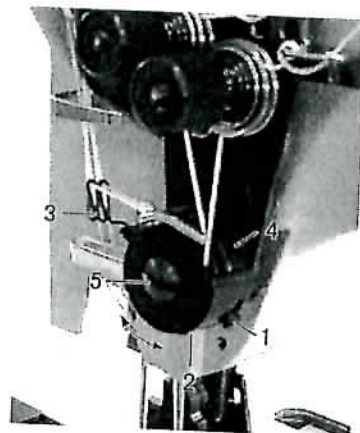

Fig. 30



## 20. ADJUSTMENT OF THE THREAD CONTROLLER SPRING (Fig. 30)

- 1) For more controller action on the thread, loosen the set screw (1) at the right of the controller and set the stop lever, and for less action set the stop higher.
- 2) To strengthen the action of the controller spring on the thread, loosen the spring stud screw (4) at the rear of the stop screw and turn the spring stud (5) slightly to the left with a screwdriver, or lighten its action turn to the right and securely retighten the spring stud screw.

## 21. REPLACEMENT OF THE CONNECTION BELT (Figs. 31, 32, 33 & 34)

- 1) when the connection belt removed from the pulley for adjusting and or replacing purposes of the parts, it should be replaced by the processes, as followings: (Figs. 31 & 32)
  - (1) Turn the machine pulley toward you so that placed the take-up lever (A) at the highest position.
  - (2) Turn the hook shaft with the fingers until the arrow mark on the hook driving shaft bushing collar (2) and the red point mark on the hook driving shaft bushing (1) are directly in line. Then replace the belt over the upper and lower pulley.

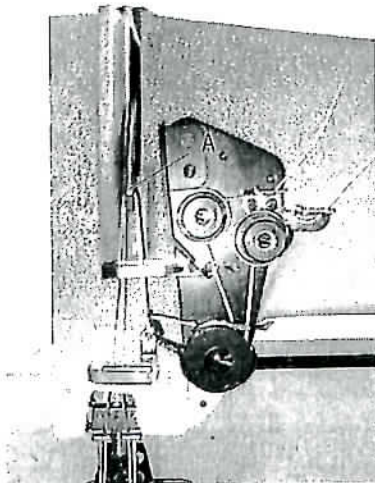

Fig.31

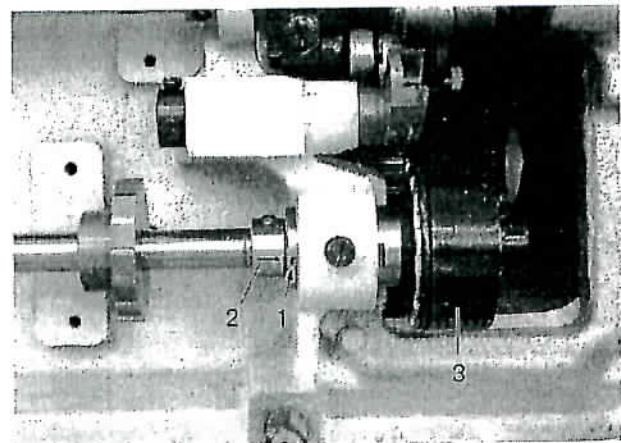

Fig.32

- 2) Replacement of the connection belt when damaged. (Figs. 33 & 34)
  - (1) Remove the upper arm plate (1) and reservoir.
  - (2) Slide the connection belt (A) off from lower and upper belt pulley.
  - (3) Remove the machine pulley (3) .
  - (4) Remove the arm shaft bushing (2) .
  - (5) Lift the belt up through the arm cap hole after removed the arm shaft bushing(2) as far as possible and draw it out through the space normally occupied by the bushing.
  - (6) Replace the connection belt as opposite processes as above for removing it.
  - (7) Securely tighten all the screws, so as to fit the arm shaft, firmly, free from looseness.

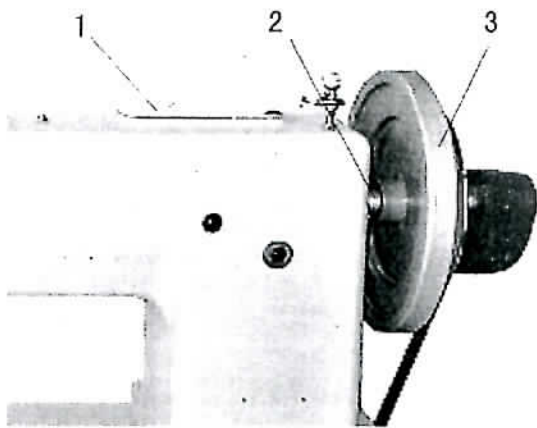

Fig.33

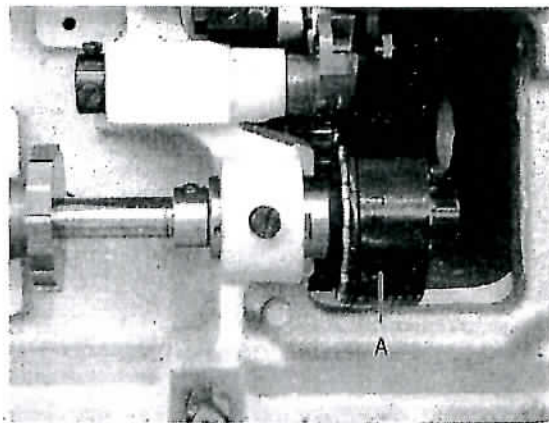

Fig.34

## 22. TO RE-ENGAGE THE SAFETY CLUTCH (Figs. 35 & 36)

The hook driving shaft and the shaft of the sewing hook are splined to prevent the hook from getting out of time. The safety clutch located in the lower belt pulley prevents damage in the event of thread jamming in the sewing hook by releasing the locking lever in the pulley.

- 1) Take out jammed thread from the hook.
- 2) To re-engage the clutch, press down the lock stud (A), near the base of the arm by left hand and turn the machine pulley backward slowly by right hand, then the safety clutch will be released.
- 3) In the case easily releasing the safety clutch, adjust the pressure by the screw (B) for lower belt pulley after removed connection belt.

To increase the pressure in turning the screw (B) to clockwise and to decrease the pressure in turning the screw (B) to counter-clockwise.

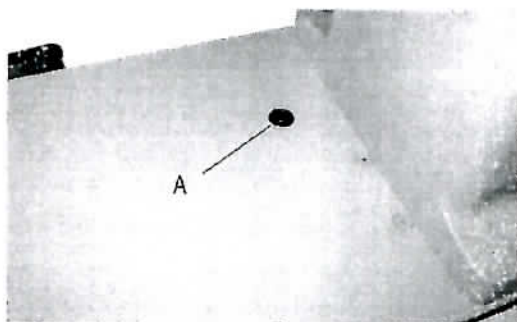

Fig.35

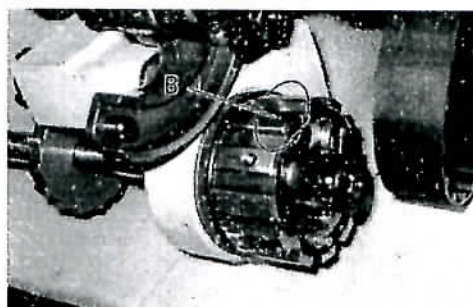
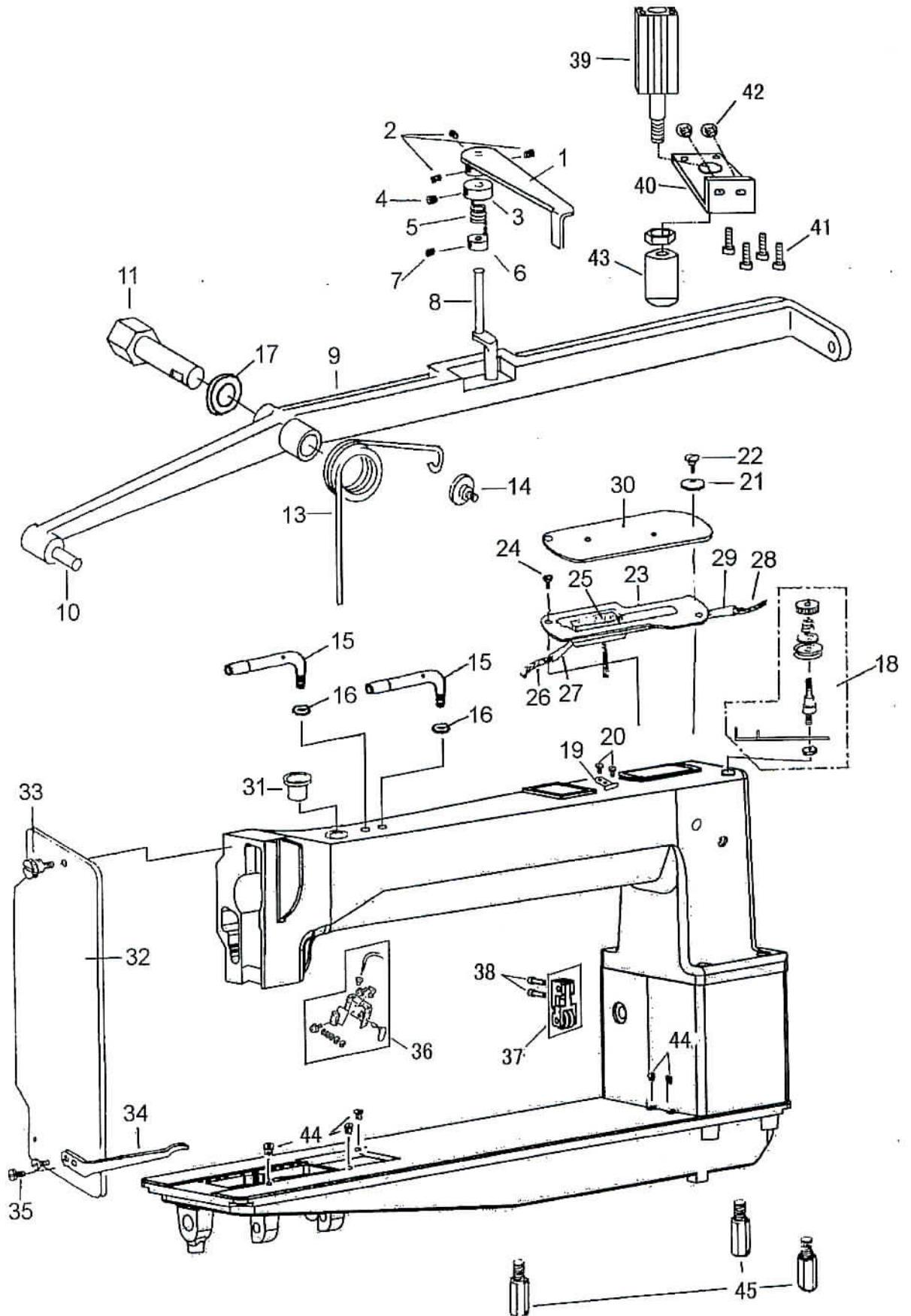

Fig.36

# A. ARM BED AND ITS ACCESSORIES





# A. ARM BED AND IT'S ACCESSORIES

Fig. Nos	Parts. Nos	Description	GC24698-6	GC24698-5L	GC24698-5R	Notes
A01	HE924B7101	Foot lifter lifting lever latch handle	1	1	1	
A02	HA100B2110	Screw	3	3	3	SM11/64(40) × 5.5
A03	HE913B8001	Collar(upper)	1	1	1	
A04	H7214H8001	Screw	1	1	1	SM11/64(40) × 4.5
A05	HE915B8001	Foot lifter lifting lever latch spring	1	1	1	
A06	HE916B8001	Collar(lower)	1	1	1	
A07	HA100C2170	Screw	1	1	1	SM1/8(44) × 4.5
A08	HE917B8001	Foot lifter lifting lever latch shaft	1	1	1	
A09	HF410B8001	Foot lifter lifting lever	1	1	1	
A10	HE919B8001	Pin	1	1	1	
A11	HE920B8001	Foot lifter lifting lever hinge stud	1	1	1	
A13	HF411B8001	Foot lifter lifting lever spring	1	1	1	
A14	HE048D8001	Screw	1	1	1	SM17/64(24) × 8
A15	HE020B8001	Thread guide	1	1	2	
A16	HE021B8001	Nut	1	1	2	SM7/32(32)
A17	H32121I304	Washer	1	1	1	
A18	HE969B7101	Thread tension mechanism	1	1	1	
A19	H6756B8001	Thread cutter	1	1	1	
A20	HA500C2070	Screw	2	2	2	SM9/64(40) × 8
A21	HE045D8001	Washer	1	1	1	
A22	HE927B8001	Screw	1	1	1	SM3/16(28) × 6.5
A23	HE928B8001	Lubricating oil cap	1	1	1	
A24	HE111F8001	Set screw	1	1	1	SM1/8(44) × 7
A25	HE929B8001	Oil pad	1	1	1	
A26	HE930B8001	Oil wick	1	1	1	
A27	HE931B8001	Vinly tube	1	1	1	
A28	HE932B8001	Oil wick	1	1	1	
A29	HE933B8001	Vinly tube	1	1	1	
A30	HE934B8001	Arm oil cap	1	1	1	
A31	H7327B8001	Arm oil plug	1	1	1	
A32	HE937B8001	Face plate	1	1	1	
A33	HE938B8001	Face plate thumb screw	1	1	1	SM13/64(32) × 7
A34	HE939B8001	Thread guide(lower)	1	1	1	
A35	HE025C8001	Screw	2	2	2	SM1/8(40) × 3.3
A36	HG01B37101	Touch switch assy.	1	1	1	
A37	HD808B7101	ensioning wheel assy.	1	1	1	
A38	H415050140	Screw	2	2	2	
A39	H0313L8001	Cylinder	1	1	1	SDA32 × 50-B
A40	HF415B8001	Cylinder bracket	1	1	1	
A41	H415060150	Screw	4	4	4	
A42	HE010M8001	Screw	2	2	2	SM17/64(24) × 8
A43	HF416B8001	Cylinder joint	1	1	1	
A44	H2000M0090	Ball oil	5	5	5	
A45	HE956B8001	Supporting bolt	3	3	3	

# B. ARM SHAFT MECHANISM

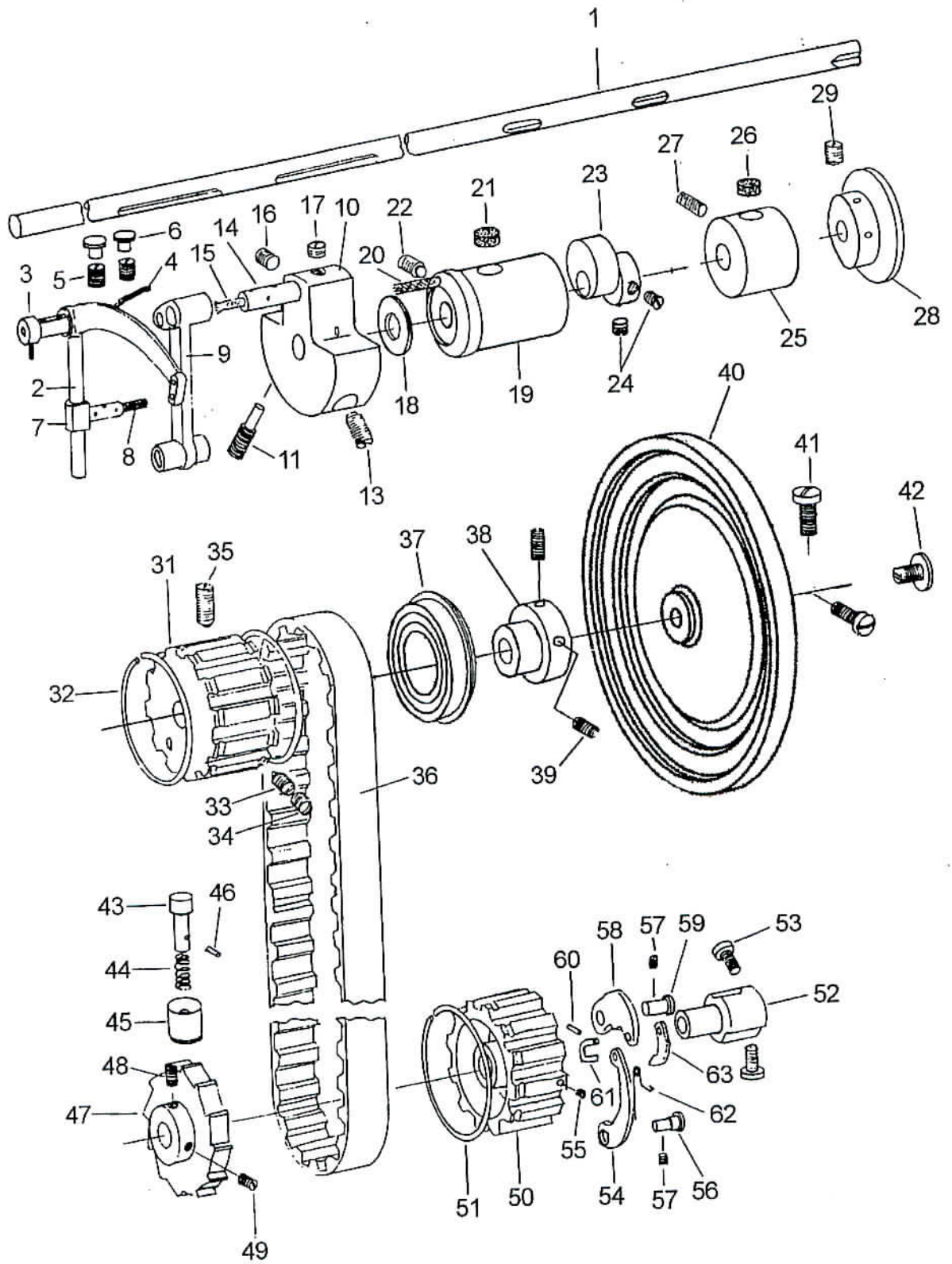

## B. ARM SHAFT MECHANISM

Fig. Nos	Parts. Nos	Description	GC24698-6	GC24698-5L	GC24698-5R	Notes
B01	HF404C8001	Arm shaft	1	1	1	
B02	HE905C8001	Thread take-up lever	1	1	1	
B03	HE906C8001	Thread take-up lever hinge stud	1	1	1	
B04	HE907C8001	Oil wick	1	1	1	
B05	HE020C8001	Set screw	2	2	2	
B06	HA100B2150	Rubber plug	2	2	2	
B07	HE908C8001	Thread take-up slide block	1	1	1	
B08	HE035C8001	Oil wick	1	1	1	
B09	HE909C8001	Needle bar connecting link	1	1	1	
B10	HE910C8001	Needle bar crank	1	1	1	
B11	HA100C2070	Position screw	1	1	1	
B13	HA100C2060	Set screw	1	1	1	
B14	H3100C2070	Needle bar connecting link stud	1	1	1	
B15	HE041C8001	Oil wick	1	1	1	
B16	HE013C8001	Set screw	1	1	1	SM17/64(24) × 6.5
B17	HE911C8001	Set screw	1	1	1	SM17/64(24) × 3.5
B18	HE011C8001	Washer	1	1	1	
B19	HE912C8001	Arm shaft bushing(left)	1	1	1	
B20	HE010G8001	Oil wick	1	1	1	
B21	HE014C8001	Oil pad	1	1	1	
B22	HE020C8001	Set screw	1	1	1	SM17/64(24) × 20
B23	HE914C8001	Feed driving eccentric	1	1	1	
B24	HE023C8001	Set screw	2	2	2	
B25	HE916C8001	Arm shaft center bushing	1	1	1	
B26	HE014C8001	Oil pad	1	1	1	
B27	HE020C8001	Set screw	1	1	1	
B28	HE939G8001	Pulley	1	1	1	
B29	H6623C8001	Screw	2	2	2	M4 × 8
B31	HE026C8001	Belt pulley(upper)	1	1	1	
B32	H3205C9661	Spring flange	2	2	2	
B33	HE006D8001	Set screw	1	1	1	
B34	HE030C8001	Check screw	1	1	1	
B35	HE028C8001	Position screw	1	1	1	
B36	HE917C8001	Connection belt	1	1	1	
B37	H3205J0662	Bearing	1	1	1	
B38	HF405C8001	Arm shaft bushing(right)	1	1	1	
B39	HA100C2020	Screw	2	2	2	SM15/64(28)
B40	HF407C8001	Machine pulley	1	1	1	
B41	HE038E8001	Set screw	2	2	2	
B42	HE007C8001	Machine pulley adjusting screw	1	1	1	
B43	HE921C8001	Hook driving shaft lock stud.	1	1	1	
B44	HA107D0672	Spring	1	1	1	
B45	HE922C8001	Shaft bushing	1	1	1	



## B. ARM SHAFT MECHANISM

Fig. Nos	Parts. Nos	Description	GC24698-6	GC24698-5L	GC24698-5R	Notes
B46	H601016100	Stop stud	1	1	1	
B47	HE923C8001	Hook driving shaft lock ratchet.	1	1	1	
B48	HE035G8001	Set screw	1	1	1	
B49	HE034G8001	Position screw	1	1	1	
B50	HE924C8001	Belt pulley(lower)	1	1	1	
B51	H3205C0661	Spring flange	1	1	1	
B52	HF408C8001	Lower shaft	1	1	1	
B53	HE022G8001	Screw	2	2	2	
B54	HE925C8001	Long lever for pulley	1	1	1	
B55	HE926C8001	Set screw	1	1	1	SM5/32 (40) × 3.6
B56	HE927C8001	Pin	1	1	1	
B57	HE028E8001	Set screw	2	2	2	
B58	HE028G8001	Short lever for pulley	1	1	1	
B59	HE029G8001	Stud	1	1	1	
B60	H601012050	Stop pin	1	1	1	
B61	HE027G8001	Pin	1	1	1	
B62	HE026G8001	Spring	1	1	1	
B63	HE031G8001	Rob	1	1	1	

# C. PRESSER FOOT MECHANISM

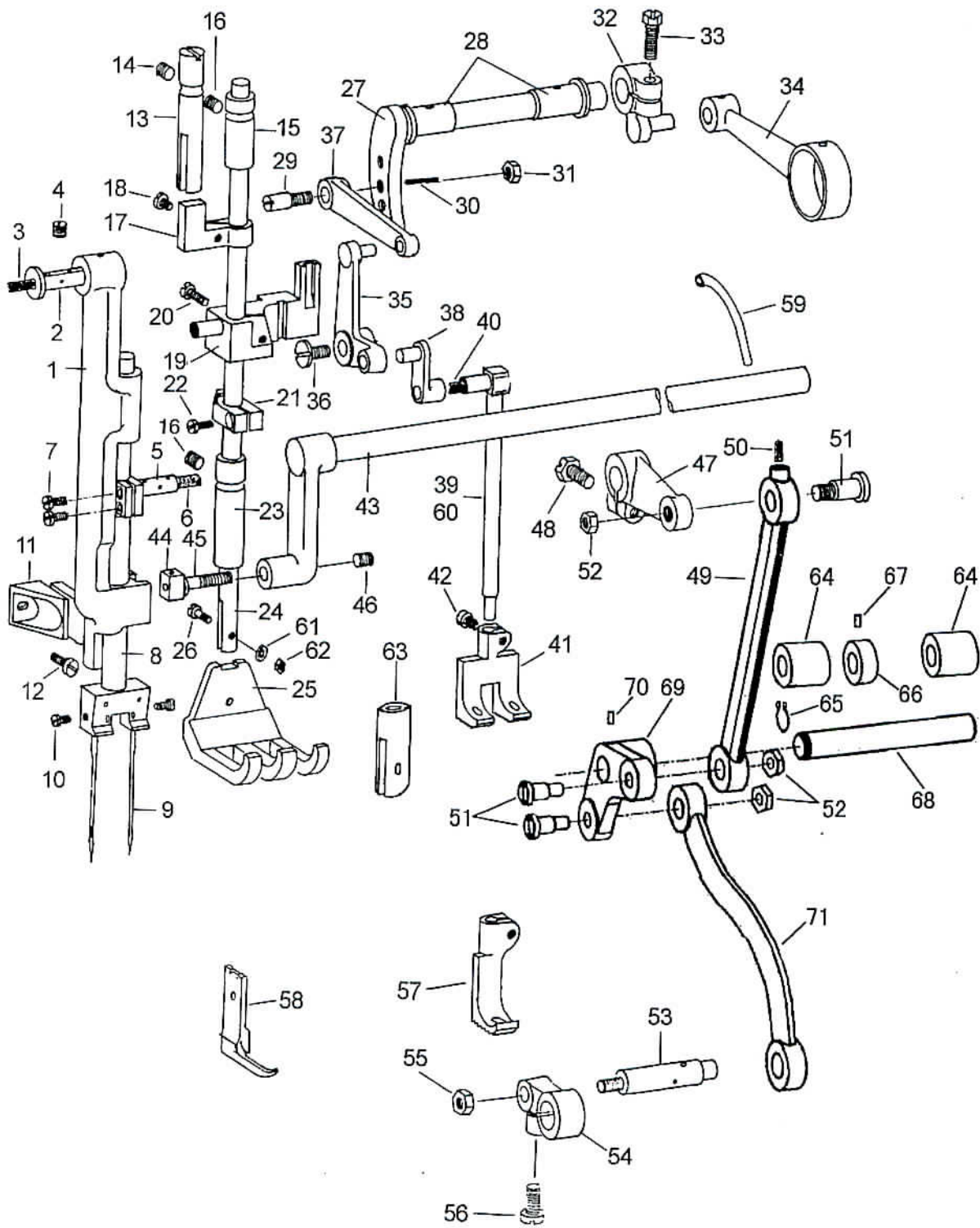

From the library of: Diamond Needle Corp

## C. PRESSER FOOT MECHANISM

Fig. Nos	Parts. Nos	Description	GC24698-6	GC24698-5L	GC24698-5R	Notes
C01	HE904D8001	Needle bar guide bracket	1	1	1	
C02	HE905D8001	Needle bar guide bracket stud	1	1	1	
C03	HE035C8001	Oil wick	1	1	1	
C04	HE009G8001	Set screw	1	1	1	
C05	HE907D8001	Needle bar connection stud	1	1	1	
C06	HE041C8001	Oil wick	1	1	1	
C07	HE119E8001	Set screw	2	2	2	SM5/32 (40) × 9
C08	HE908D8001	Needle bar(3/4")	1			
C09	HE909D8001	Needle	2	1	1	DY × 3 #25
C10	HE910D8001	Needle set screw	2	1	1	SM3/16 (32) × 5. 5
C11	HE911D8001	Position bracket	1	1	1	
C12	HE022K8001	Screw	1	1	1	SM11/64 (32) × 9
C13	HE912D8001	Presser bar position guide	1	1	1	
C14	HE006D8001	Set screw	1	1	1	SM17/64 (24) × 11
C15	HE007D8001	Presser bar bushing(upper)	1	1	1	
C16	HE006D8001	Set screw	2	2	2	
C17	HE913D8001	Presser bar position guide lever	1	1	1	
C18	HE009D8001	Set screw	1	1	1	SM5/32 (40) × 6. 5
C19	HE914D8001	Presser bar lifting bracket	1	1	1	
C20	H3107G0661	Set screw	1	1	1	SM11/64 (40) × 14
C21	HE915D8001	Presser bar spring bracket	1	1	1	
C22	HE916D8001	Set screw	1	1	1	SM3/16 (32) × 13. 5
C23	HE007D8001	Presser bar bushing(lower)	1	1	1	
C24	HE918D8001	Presser bar	1	1	1	
C25	HE919D8001	Lifting presser foot(3/4")	1			
C26	HE920D8001	Set screw	1	1	1	SM0. 1339 (36) × 16. 7
C27	HE921D8001	Feed lifting rock shaft	1	1	1	
C28	HE024D8001	Lifting rock shaft bushing	2	2	2	
C29	HE025D8001	Screw stud	1	1	1	
C30	HE035C8001	Oil wick	1	1	1	
C31	H3112F0662	Nut	1	1	1	
C32	HE922D8001	Lifting eccentric	1	1	1	
C33	HE038E8001	Position screw	1	1	1	
C34	HE923D8001	Lifting eccentric connection	1	1	1	
C35	HE924D8001	Lifting bell crank	1	1	1	
C36	H3107G0662	Set screw	1	1	1	SM11/64 (40)
C37	HE925D8001	Lifting bell crank link	1	1	1	
C38	HE926D8001	Link	1	1	1	
C39	HE927D8001	Vibrating presser bar	1	1	1	
C40	HE035C8001	Oil wick	1	1	1	
C41	HE928D8001	Vibrating presser foot(3/4")	1			
C42	HE929D8001	Set screw	1	1	1	SM11/64 (40) × 7. 5
C43	HF404D7101	Needle bar vibrating crank shaft	1	1	1	



### C. PRESSER FOOT MECHANISM

Fig. Nos	Parts. Nos	Description	GC24698-6	GC24698-5L	GC24698-5R	Notes
C44	H3100F2270	Needle bar rock frame slide block	1	1	1	
C45	HE027E8001	Screw stud	1	1	1	
C46	HE028E8001	Set screw	1	1	1	
C47	HE933D8001	Needle bar vibrating crank(right)	1	1	1	
C48	HE038E8001	Set screw	1	1	1	
C49		Connection link	1	1	1	
C50	HE035C8001	Oil wick	1	1	1	
C51	HE935D8001	Hinge screw	1	1	1	
C52	HE936D8001	Nut	1	1	1	SM17/64 (24)
C53	HE937D8001	Feed connecting screw stud	3	1	1	
C54	HE938D8001	Feed connecting crank(left)	3	1	1	
C55	HE926E8001	Nut	1	1	1	SMO. 309 (20)
C56	HE038E8001	Stop screw	1	1	1	
C57	HF207D8001	Vibrating presser foot		1	1	
C58	HF304D8001	Lifting presser foot		1	1	
C59	HE939D8001	Vinyl tube	1	1	1	
C60	HF209D8001	Vibrating presser bar(single needle)	1	1	1	
C61	HE044J8001	Washer	1	1	1	
C62	HE940D8001	Nut	1	1	1	SMO. 1339 (36) × 16.7
C63	HE941D8001	Bushing	1	1	1	
C64	HD611B8001	Bushing	2	2	2	
C65	H007009100	Stop ring	1	1	1	
C66	HD712F8001	Collar	1	1	1	
C67	H431040040	Screw	1	2	2	
C68	HY11D18001	Shaft	1	1	1	
C69	HY10D98001	Crank	1	1	1	
C70	H431060	Screw	1	1	1	
C71	HY11D08001	Connecting rod	1	1	1	

# D. STITCH REGULATOR AND FEED ROCKING MECHANISM

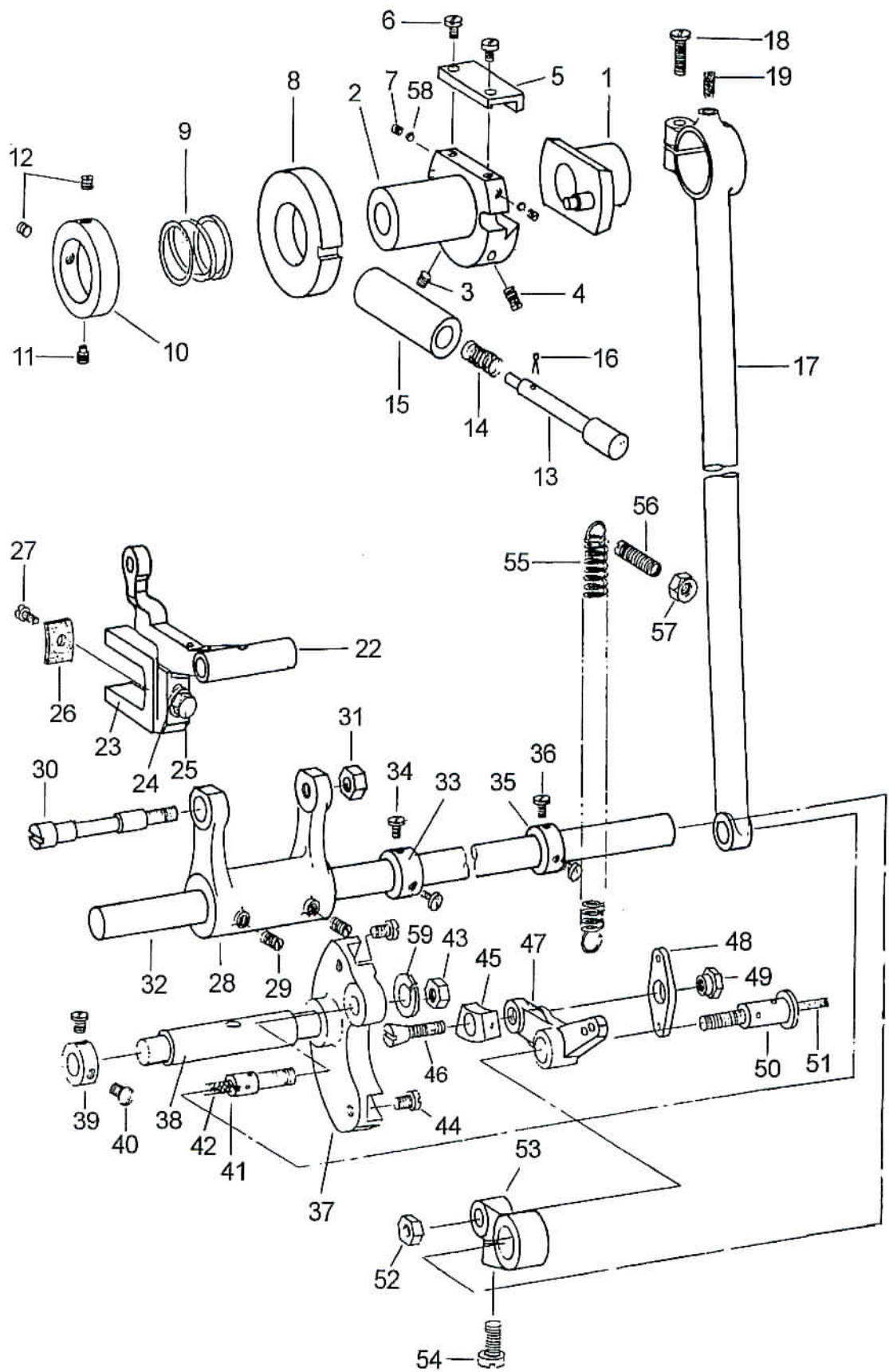

## D. STITCH REGULATOR AND FEED ROCKING MECHANISM

Fig. Nos	Parts. Nos	Description	GC24698-6	GC24698-5L	GC24698-5R	Notes
D01	HE946E8001	Feed driving eccentric	1	1	1	
D02	HE905E8001	Flange	1	1	1	
D03	HE906E8001	Set screw	1	1	1	SM3/16(32) × 10.5
D04	HE907E8001	Set screw	1	1	1	SM3/16(32) × 10.5
D05	HE908E8001	Friction plate	1	1	1	
D06	HE909E8001	Stop screw	2	2	2	SM3/16(40) × 11.5
D07	HA100B2110	Set screw	2	2	2	
D08	HE910E8001	Feed driving eccentric adjusting disc	1	1	1	
D09	HE911E8001	Spring	1	1	1	
D10	HE912E8001	Collar	1	1	1	
D11	HE035G8001	Position screw	1	1	1	
D12	HE023C8001	Set screw	2	2	2	
D13	HE913E8001	Feed regulating stud	1	1	1	
D14	HE914E8001	Spring	1	1	1	
D15	HE915E8001	Bushing	1	1	1	
D16	H601015100	Snap pin	1	1	1	
D17	HY10E68001	Feed driving connection	1	1	1	
D18	H3107G0661	Pinch screw	1	1	1	
D19	HE035C8001	Oil wick	1	1	1	
D20						
D21						
D22	HY10E88001	Feed bar	1	1	1	
D23	HE920E8001	Feed bar forked connection	1	1	1	
D24	H2013J0065	Washer	1	1	1	
D25	HE022H8001	Screw	1	1	1	
D26	HE020H8001	Oil pad	1	1	1	
D27	HE025B8001	Screw	1	1	1	
D28	HE921E8001	Feed bar crank	1	1	1	
D29	HE922E8001	Set screw	2	2	2	SM17/64" (24) × 7.7
D30	HE923E8001	Feed bar hinge screw	1	1	1	
D31	HE131E8001	Nut	1	1	1	
D32	HF404E8001	Feed driving rock shaft	1	1	1	
D33	HE033H8001	Feed driving rock shaft stop collar(left)	1	1	1	
D34	HE034H8001	Set screw	2	2	2	
D35	HE033H8001	Feed driving rock shaft stop collar(right)	1	1	1	
D36	HE034H8001	Set screw	2	2	2	
D37	HE943E7101	Feed reversing lever	1	1	1	
D38	HE928E8001	Feed reversing lever bushing	1	1	1	
D39	HE929E8001	Collar	1	1	1	
D40	HE012E8001	Set screw	1	1	1	
D41	HE930E8001	Hinge screw	1	1	1	
D42	HE035C8001	Oil wick	1	1	1	
D43	HE926E8001	Nut	1	1	1	



## D. STITCH REGULATOR AND FEED ROCKING MECHANISM

Fig. Nos	Parts. Nos	Description	GC24698-6	GC24698-5L	GC24698-5R	Notes
D44	HE931E8001	Stop screw	2	2	2	SM3/16(32) × 4
D45	HE932E8001	Feed reversing lever slide block	1	1	1	
D46	HE933E8001	Set screw	1	1	1	
D47	HY12E68001	Feed reversing link	1	1	1	
D48	HE935E8001	Spring and treadle connecting link	1	1	1	
D49	HE936E8001	Hinge screw nut	1	1	1	
D50	HE937E8001	Hinge screw	1	1	1	
D51	HE035C8001	Oil wick	1	1	1	
D52	HE926E8001	Nut	1	1	1	
D53	HE938E8001	Feed reversing crank(right)	1	1	1	
D54	HE939E8001	Set screw	2	2	2	M6 × 20
D55	HY12E88001	Feed reversing lever slide block spring	1	1	1	
D56	HE940E8001	Set screw	1	1	1	SM5/16(24) × 17.5
D57	HE941E8001	Nut	1	1	1	SM5/16(24)
D58	HE942E8001	Washer	2	2	2	
D59	H005010080	Spring washer	1	1	1	

# E. HOOK SADDLE MECHANISM

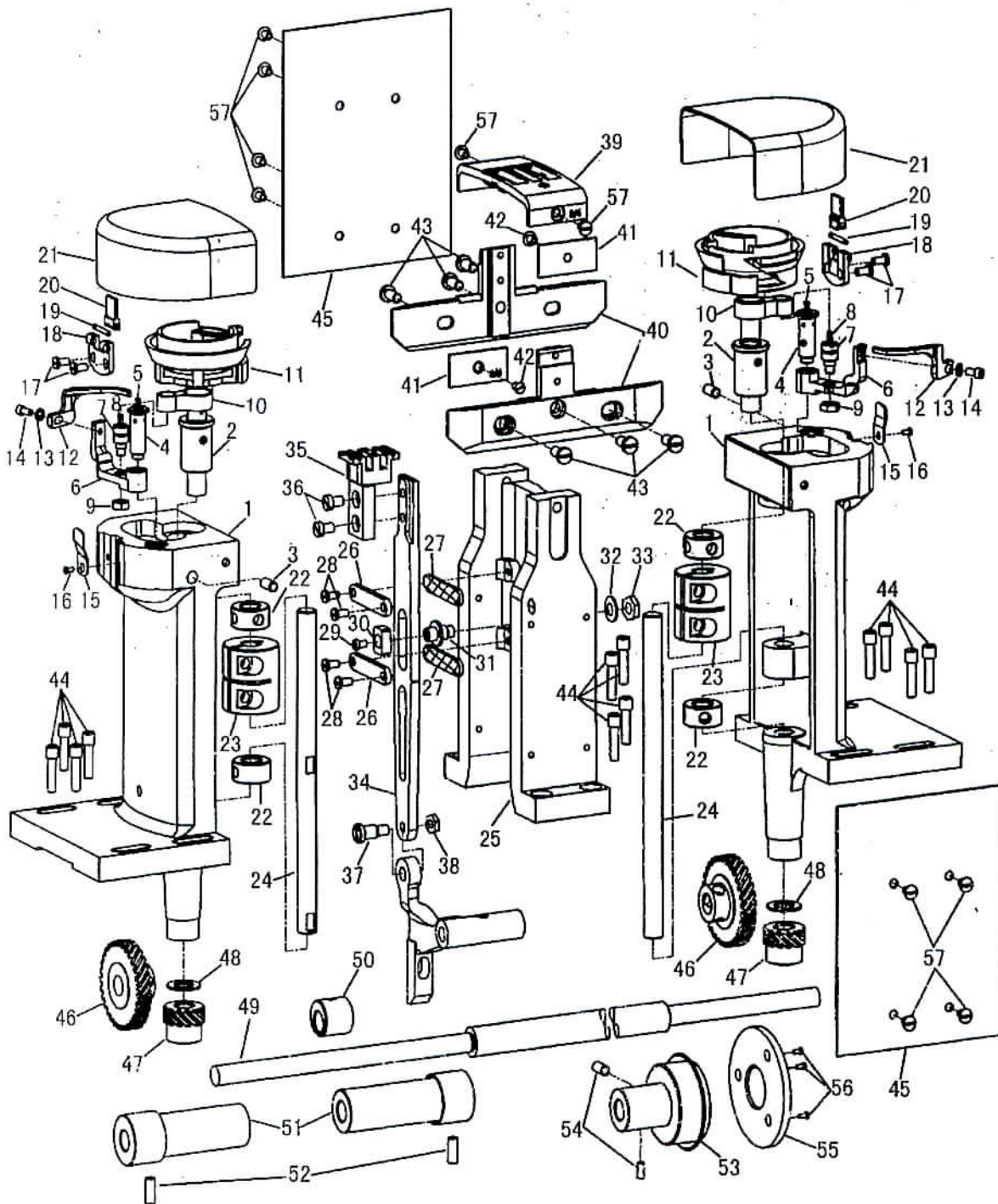

From the library of: Diamond Needle Corp

## E. HOOK SADDLE MECHANISM

Fig. Nos	Parts. Nos	Description	GC24698-6	Notes
E01	HY10F68001	Hook shaft supporter	2	
E02	HY11F98001	Bushing	2	
E03	HE053C8001	Screw	2	SM7/32×32
E04	HY11F28001	Bobbin case opener lever hinge shaft	2	
E05	HE018J8001	Oil pad	2	
E06	HY11F08001	Bobbin case opener lever	2	
E07	HE017J8001	Locating stud	2	
E08	HE018J8001	Oil pad	2	
E09	HE019J8001	Nut	2	
E10	HE912F8001	Bobbin case opener lever link	2	
E11	HE911F8001	Hook	2	
E12	HY11F18001	Bobbin case opener	2	
E13	H005004050	Washer	2	
E14	HE909F8001	Screw	2	
E15	HE524J8001	Spring	2	
E16	HE517J8001	Screw	2	
E17	HE517J8001	Screw	4	
E18	HE521J8001	Hinge	2	
E19	HE522J8001	Pin	2	
E20	HE520J8001	Hinge	2	
E21	HY12F18001	Hook cover	2	
E22		Collar assy.	4	
	H9017H8001	Collar	4	
	H7206E8001	Screw	8	SM15/64×28 L=6
E23	HY10F77101	Clutch assy.	2	
	HY10F88001	Clutch	2	
	H415050160	Screw	4	
	H005008050	Spring washers	4	
E24	HY10F98001	Connecting shaft	2	
E25	HY12E38001	Feed plate set bracket	1	
E26	HE533J8001	Supporter plate	2	
E27	HE532J8001	Felt	2	
E28	HE517J8001	Screw	4	
E29	HE123I8001	Screw	1	
E30	HE535J8001	Square block	1	
E31	HE536J8001	Screw	1	
E32	HE045D8001	Washer	1	
E33	HE021B8001	Nut	1	
E34	HY12E18001	Feed bar	1	
E35	HY11E08001	Feed dog (3/4)	1	
E36	HE012E8001	Screw	1	
E37	HE539J8001	Screw	1	
E38	HE540J8001	Nut	1	



# E. HOOK SADDLE MECHANISM

Fig. Nos	Parts. Nos	Description	GC24698-6	Notes
E39	HY11F78001	Throat plate(3/4")	1	
E40	HY11F48001	Bracket(3/4)	2	
E41	HY11F58001	Plate(3/4)	2	
E42	HA7121N304	Screw	2	
E43	HE543J8001	Screw	6	
E44	H415060300	Screw	12	
E45	HY12F28001	Cover plate	2	
E46		Big gear assy.	2	
	HE055G8001	Gear	2	
	HE920F8001	Screw	2	
	HE921F8001	Screw	2	
E47		Small gear assy.	2	
	HE010J8001	Gear	2	
	HE017G8001	Screw	2	
	HE012J8001	Screw	2	
E48	HE013J8001	Washer	2	
E49	HY11F38001	Hook driving shaft	1	
E50		Feed lifting cam assy.	1	
	HE058G8001	Feed lifting cam	1	
	HE017G8001	Screw	1	
E51	HE928F7101	Hook driving shaft bushing assy.	2	
	HE914F8001	Hook driving shaft bushing 3/4"	2	
	H4707H8001	Oil wick	2	
E52	HE020C8001	Screw	2	
E53	HF405F7101	Shaft assembly	1	
	H4726H8001	bearing 6203Z NTN	1	φ 40 × φ 17 × 12
	HF406F8001	Hook driving shaft bushing	1	
E54	HA307C0662	Screw	2	SM1/4 (40) × 6
E55	H4727H8001	Holder	1	
E56	HA7311C306	Screw	3	
E57	HE517J8001	Screw	10	

# E. HOOK SADDLE MECHANISM

Fig. Nos	Parts. Nos	Description	GC24698-6	Notes
E39	HY11F78001	Throat plate(3/4")	1	
E40	HY11F48001	Bracket (3/4)	2	
E41	HY11F58001	Plate(3/4)	2	
E42	HA7121N304	Screw	2	
E43	HE543J8001	Screw	6	
E44	H415060300	Screw	12	
E45	HY12F28001	Cover plate	2	
E46		Big gear assy.	2	
	HE055G8001	Gear	2	
	HE920F8001	Screw	2	
	HE921F8001	Screw	2	
E47		Small gear assy.	2	
	HE010J8001	Gear	2	
	HE017G8001	Screw	2	
	HE012J8001	Screw	2	
E48	HE013J8001	Washer	2	
E49	HY11F38001	Hook driving shaft	1	
E50		Feed lifting cam assy.	1	
	HE058G8001	Feed lifting cam	1	
	HE017G8001	Screw	1	
E51	HE928F7101	Hook driving shaft bushing assy.	2	
	HE914F8001	Hook driving shaft bushing 3/4"	2	
	H4707H8001	Oil wick	2	
E52	HE020C8001	Screw	2	
E53	HF405F7101	Shaft assembly	1	
	H4726H8001	bearing 6203Z NTN	1	φ 40 × φ 17 × 12
	HF406F8001	Hook driving shaft bushing	1	
E54	HA307C0662	Screw	2	SM1/4 (40) × 6
E55	H4727H8001	Holder	1	
E56	HA7311C306	Screw	3	
E57	HE517J8001	Screw	10	

# F. HOOK SADDLE MECHANISM GC24698-5L

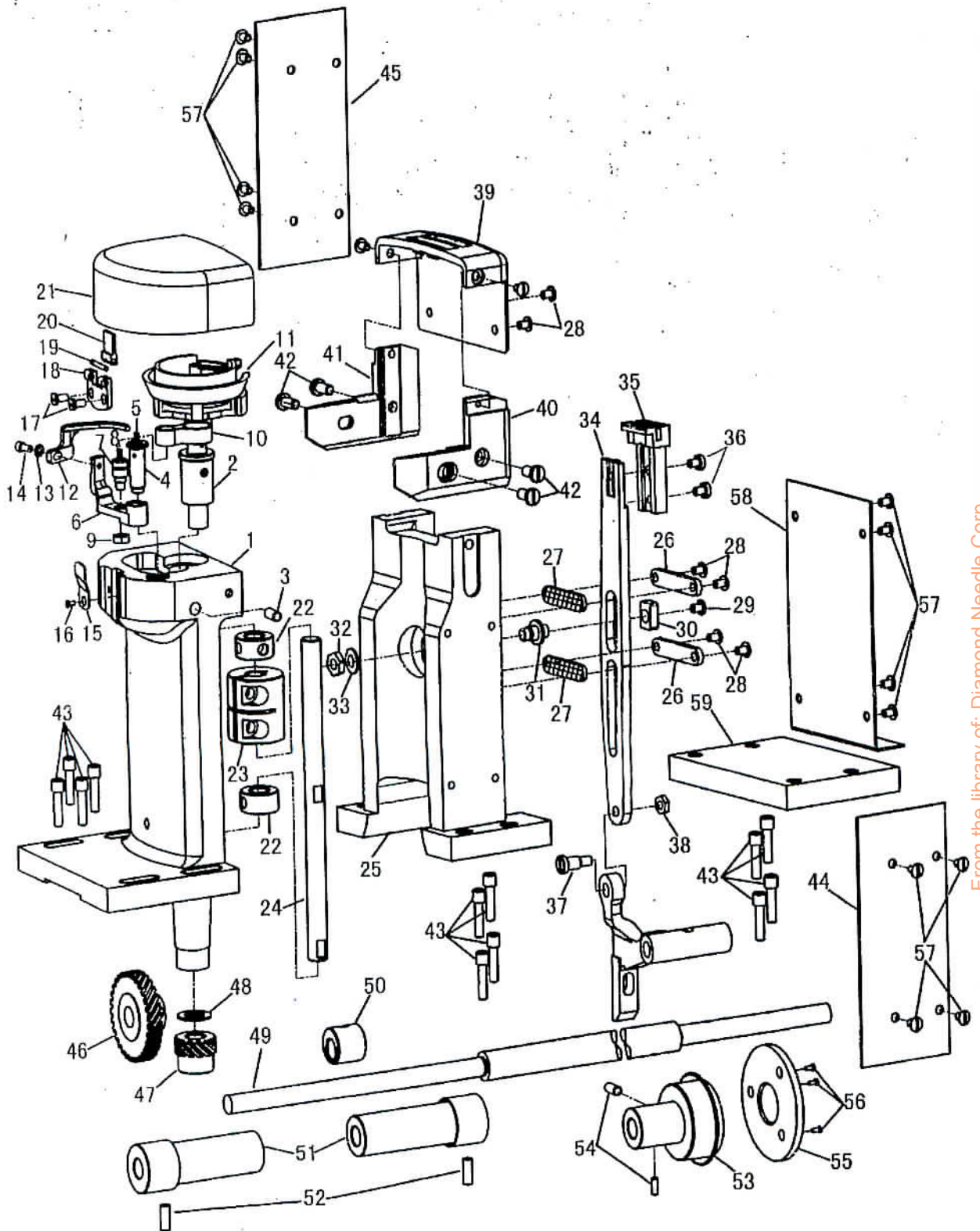

From the library of: Diamond Needle Corp



# F. HOOK SADDLE MECHANISM GC24698-5L

Fig. Nos	Parts. Nos	Description	GC24698-5L	Notes
F01	HY10F68001	Hook shaft supporter	2	
F02	HY11F98001	Bushing	2	
F03	HE053C8001	Screw	2	SM7/32×32
F04	HY11F28001	Bobbin case opener lever hinge shaft	2	
F05	HE018J8001	Oil pad	2	
F06	HY11F08001	Bobbin case opener lever	2	
F07	HE017J8001	Locating stud	2	
F08	HE018J8001	Oil pad	2	
F09	HE019J8001	Nut	2	
F10	HE912F8001	Bobbin case opener lever link	2	
F11	HE911F8001	Hook	2	
F12	HY11F18001	Bobbin case opener	2	
F13	H005004050	Washer	2	
F14	HE909F8001	Screw	2	
F15	HE524J8001	Spring	2	
F16	HE517J8001	Screw	2	
F17	HE517J8001	Screw	4	
F18	HE521J8001	Hinge	2	
F19	HE522J8001	Pin	2	
F20	HE520J8001	Hinge	2	
F21	HY12F18001	Hook cover	2	
F22		Collar assy.	4	
	H9017H8001	Collar	4	
	H7206E8001	Screw	8	SM15/64×28 L=6
F23	HY10F77101	Clutch assy.	2	
	HY10F88001	Clutch	2	
	H415050160	Screw	4	
	H005008050	Spring washers	4	
F24	HY10F98001	Connecting shaft	2	
F25	HY51F28001	Feed plate set bracket	1	
F26	HE533J8001	Supporter plate	2	
F27	HE532J8001	Felt	2	
F28	HE517J8001	Screw	4	
F29	HE123I8001	Screw	1	
F30	HE535J8001	Square block	1	
F31	HE536J8001	Screw	1	
F32	HE045D8001	Washer	1	
F33	HE021B8001	Nut	1	
F34	HY12E18001	Feed bar	1	
F35	HY50F98001	Feed dog	1	
F36	HE012E8001	Screw	2	
F37	HE539J8001	Screw	1	
F38	HE540J8001	Nut	1	

F. HOOK SADDLE MECHANISM GC24698-5L

Fig. Nos	Parts. Nos	Description	GC24698-5L	Notes
F39	HY50F48001	Throat plate	1	
F40	HY50F68001	Bracket ((front)	1	
F41	HY50F58001	Bracket (behind)	1	
F42	HE543J8001	Screw	4	
F43	H415060300	Screw	12	
F44	HY51F48001	Cover plate	1	
F45	HY51F58001	Cover plate	1	
F46		Gear assembly	2	
	HE055G8001	Gear	2	
	HE920F8001	Screw	1	
	HE921F8001	Screw	1	
F47		small gear assembly	2	
	HE010J8001	Pinion	2	
	HE017G8001	Screw	1	
	HE012J8001	Screw	1	
F48	HE013J8001	.	2	
F49	HY11F38001	Hook driving shaft	1	
F50		Cam assembly	1	
	HE058G8001	Feed lifting cam	1	
	HE017G8001	Screw	1	
F51	HE928F7101	Hook driving shaft bushing assy.	2	
	HE914F8001	Hook driving shaft bushing	2	
	H4707H8001	Oil wick	2	
F52	HE020C8001	Screw	2	
F53	HF405F7101	Shaft assembly	1	
	H4726H8001	bearing 6203Z NTN	1	φ 40 × φ 17 × 12
	HF406F8001	Hook driving shaft bushing	1	
F54	HA307C0662	Screw	2	SM1/4 (40) × 6
F55	H4727H8001	Baffle plate	1	
F56	HA7311C306	Screw	3	
F57	HE517J8001	Screw	16	
F58	HY51F38001	Cover plate	1	
F59	HY51F68001	Cushion block	1	

G. HOOK SADDLE MECHANISM GC24698-5R

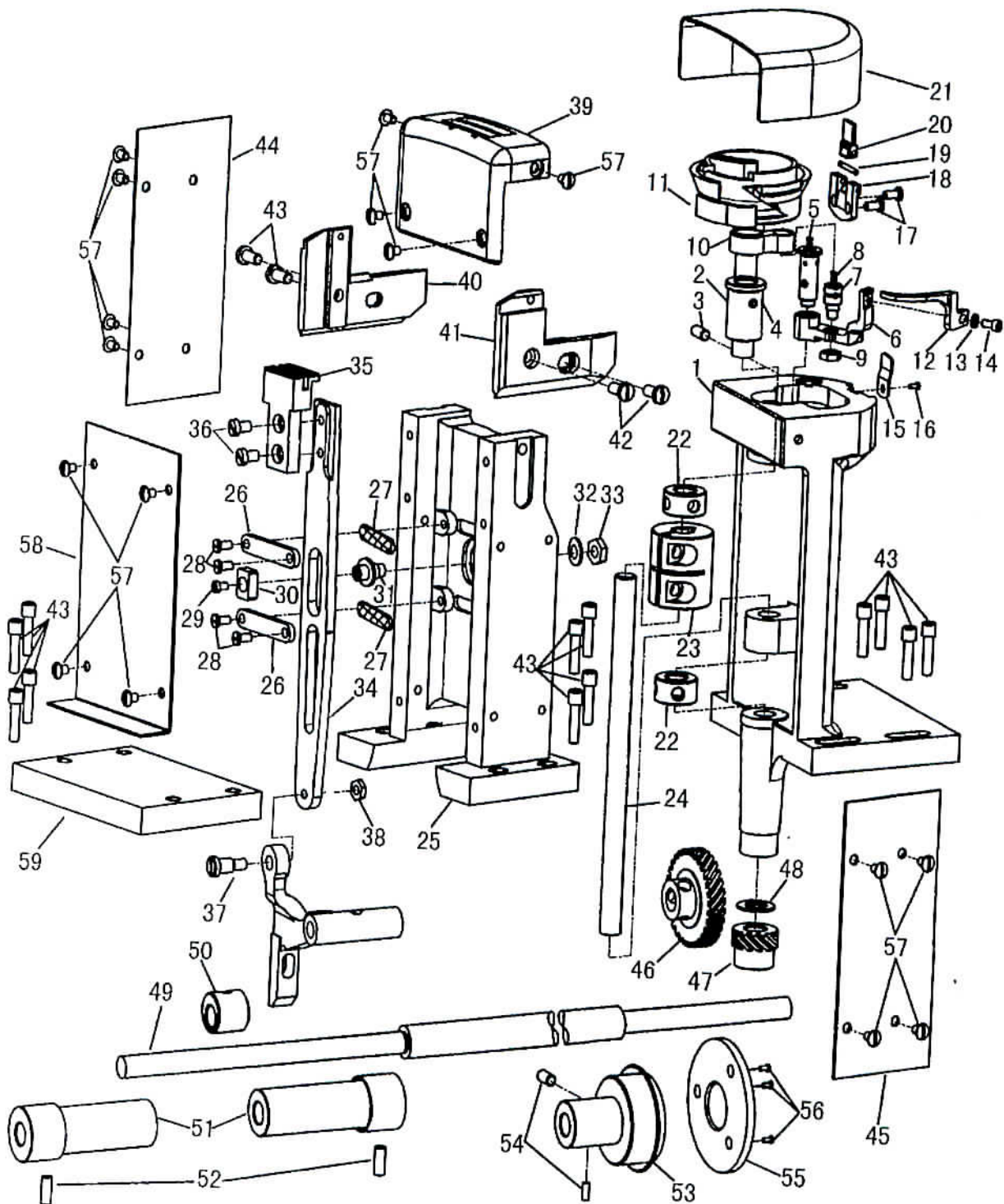

From the library of: Diamond Needle Corp



# G. HOOK SADDLE MECHANISM GC24698-5R

Fig. Nos	Parts. Nos	Description	GC24698-5R	Notes
G01	HY10F68001	Hook shaft supporter	2	
G02	HY11F98001	Bushing	2	
G03	HE053C8001	Screw	2	SM7/32×32
G04	HY11F28001	Bobbin case opener lever hinge shaft	2	
G05	HE018J8001	Oil pad	2	
G06	HY11F08001	Bobbin case opener lever	2	
G07	HE017J8001	Locating stud	2	
G08	HE018J8001	Oil pad	2	
G09	HE019J8001	Nut	2	
G10	HE912F8001	Bobbin case opener lever link	2	
G11	HE911F8001	Hook	2	
G12	HY11F18001	Bobbin case opener	2	
G13	H005004050	Washer	2	
G14	HE909F8001	Screw	2	
G15	HE524J8001	Spring	2	
G16	HE517J8001	Screw	2	
G17	HE517J8001	Screw	4	
G18	HE521J8001	Hinge	2	
G19	HE522J8001	Pin	2	
G20	HE520J8001	Hinge	2	
G21	HY12F18001	Hook cover	2	
G22		Collar assy.	4	
	H9017H8001	Collar	4	
	H7206E8001	Screw	8	SM15/64×28 L=6
G23	HY10F77101	Clutch assy.	2	
	HY10F88001	Clutch	2	
	H415050160	Screw	4	
	H005008050	Spring washers	4	
G24	HY10F98001	Connecting shaft	2	
G25	HY51F28001	Feed plate set bracket	1	
G26	HE533J8001	Supporter plate	2	
G27	HE532J8001	Felt	2	
G28	HE517J8001	Screw	4	
G29	HE123I8001	Screw	1	
G30	HE535J8001	Square block	1	
G31	HE536J8001	Screw	1	
G32	HE045D8001	Washer	1	
G33	HE021B8001	Nut	1	
G34	HY12E18001	Feed bar	1	
G35	HY60F48001	Feed dog	1	
G36	HE012E8001	Screw	1	
G37	HE539J8001	Screw	1	
G38	HE540J8001	Nut	1	

# G. HOOK SADDLE MECHANISM GC24698-5R

Fig. Nos	Parts. Nos	Description	GC24698-5R	Notes
G39	HY50F48001	Throat plate	1	
G40	HY50F68001	Bracket((front)	1	
G41	HY50F58001	Bracket(behind)	1	
G42	HE543J8001	Screw	4	
G43	H415060300	Screw	12	
G44	HY51F48001	Cover plate	1	
G45	HY51F58001	Cover plate	1	
G46		Gear assembly	2	
	HE055G8001	Gear	2	
	HE920F8001	Screw	1	
	HE921F8001	Screw	1	
G47		small gear assembly	2	
	HE010J8001	Pinion	2	
	HE017G8001	Screw	1	
	HE012J8001	Screw	1	
G48	HE013J8001	washer	2	
G49	HY11F38001	Hook driving shaft	1	
G50		Cam assembly	1	
	HE058G8001	Feed lifting cam	1	
	HE017G8001	Screw	1	
G51	HE928F7101	Hook driving shaft bushing assy.	2	
	HA7311C306	Hook driving shaft bushing	2	
	H4707H8001	Oil wick	2	
G52	HE020C8001	Screw	2	
G53	HF405F7101	Shaft assembly	1	
	H4726H8001	bearing 6203Z NTN	1	$\phi 40 \times \phi 17 \times 12$
	HF406F8001	Hook driving shaft bushing	1	
G54	HA307C0662	Screw	2	SM1/4 (40) $\times 6$
G55	H4727H8001	Baffle plate	1	
G56	HA7311C306	Screw	3	
G57	HE517J8001	Screw	16	
G58	HY51F38001	Cover plate	1	
G59	HY51F68001	Cushion block	1	

# H. THREAD TENSION REGULATOR MECHANISM

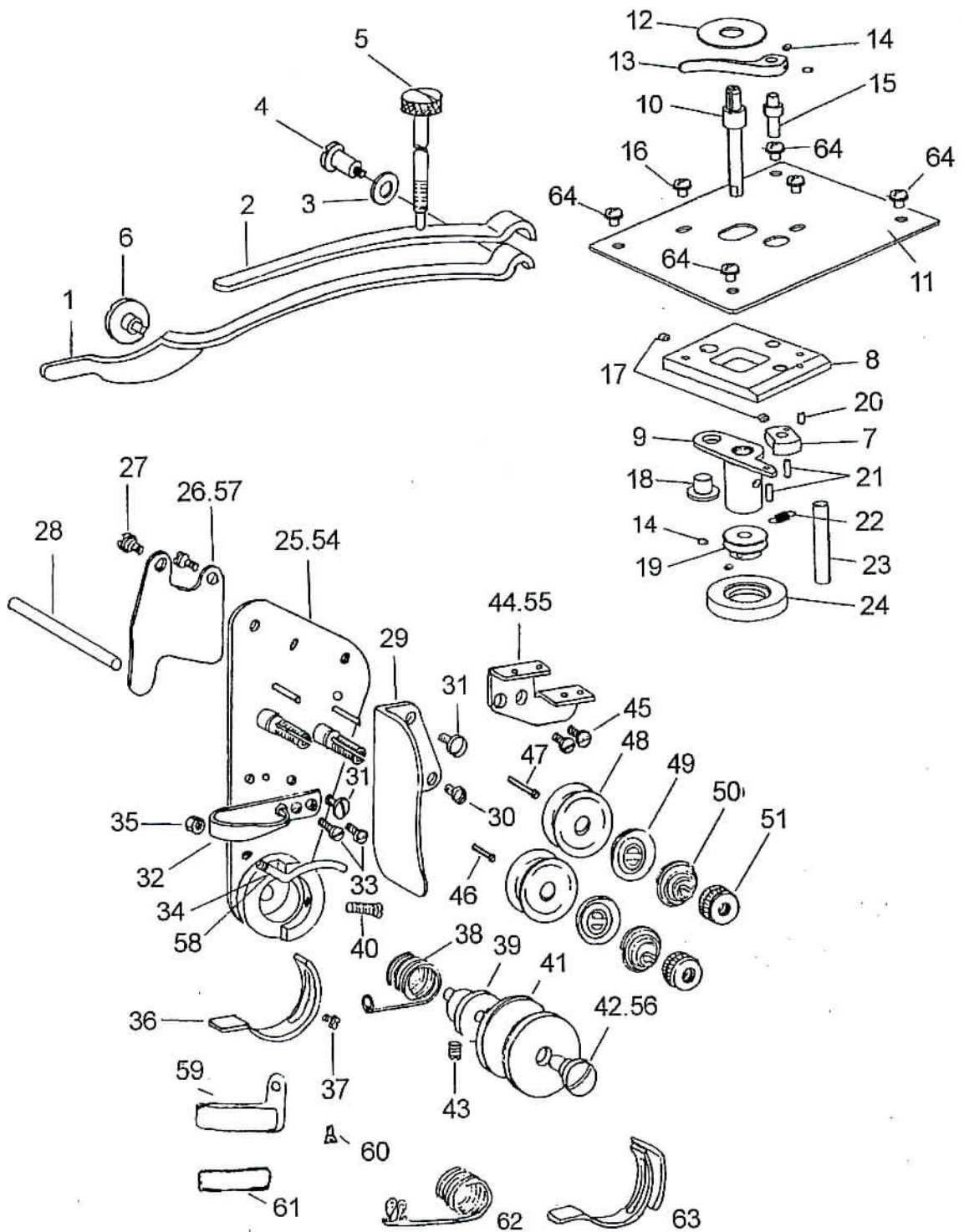

From the library of: Diamond Needle Corp



## H. THREAD TENSION REGULATOR MECHANISM

Fig. Nos	Parts. Nos	Description	GC24698-6	GC24698-5L	GC24698-5R	Notes
H01	HE904G8001	Presser bar spring (flat)	1	1	1	
H02	HE905G8001	Presser bar spring (auxiliary)	1	1	1	
H03	H005006080	Washer	1	1	1	
H04	HE907G8001	Screw	1	1	1	SM17/64 (24) × 13
H05	HE908G8001	Screw	1	1	1	
H06	HE048D8001	Screw	1	1	1	SM17/64 (24) × 8
H07	HE934G8001	Cam	1	1	1	
H08	HE935G8001	Hold plate	1	1	1	
H09	HE936G8001	Lever	1	1	1	
H10	HE937G8001	Shaft	1	1	1	
H11	HE938G8001	Hold plate	1	1	1	
H12	H6656B8001	Washer	1	1	1	
H13	H6651B8001	Lever	1	1	1	
H14	H431030040	Screw	4	4	4	
H15	H6649B8001	Shaft	1	1	1	
H16	H409040080	Screw	2	2	2	
H17	H431040040	Screw	2	2	2	
H18	H6650B8001	Pin	1	1	1	
H19	H6657B8001	Thread winder wheel	1	1	1	
H20		Pin	1	1	1	φ 2.5 × 8
H21		Pin	2	2	2	φ 2.5 × 12
H22	H6653B8001	Spring	1	1	1	
H23	H6655B8001	Spring	1	1	1	
H24	H6658B8001	Tire	1	1	1	
H25	HE924G7101	Mounting plate	1			
H26	HE910G8001	Thread tesion releasing discs	1			
H27	HE019K8001	Screw	2	2	2	
H28	HE912G8001	Thread releasing pin (long)	1	1	1	
H29	HE913G8001	Thread controller covering plate	1	1	1	
H30	HE046C8001	Stop screw	1	1	1	
H31	HE012E8001	Stop screw	2	2	2	SM11/64 (32) × 6.5
H32	HE914G8001	Thread guide	1	1	1	
H33	HE915G8001	Screw	2	2	2	SMO. 1339 (36) × 3.5
H34	HE916G8001	Thread guide	1	1	1	
H35	HE018H8001	Nut	1	1	1	
H36	HE931G8001	Stopper	1			
H37	HE046C8001	Screw	1	1	1	
H38	HF205G8001	Thread take-up spring		1	1	
H39	HE917G8001	Thread controller spring stud	1	1	1	
H40	HE022K8001	Set screw	1	1	1	
H41	HE918G8001	Thread controller disc	1	1	1	
H42	HE919G8001	Thread controller stud	1	1	1	
H43	HE920G8001	Screw	1	1	1	SM11/64 (32) × 4

## H. THREAD TENSION REGULATOR MECHANISM

Fig. Nos	Parts. Nos	Description	GC24698-6	GC24698-5L	GC24698-5R	Notes
H44	HE921G8001	Thread guide	1	1	1	
H45	HE915G8001	Set screw	2	2	2	
H46	HE922G8001	Thread releasing pin(short)	1	1	1	
H47	HE923G8001	Thread releasing pin(long)	1	1	1	
H48	HA310B0705	Thread tension discs	4	2	2	
H49	HA310B0702	Thread tension releasing discs	2	1	1	
H50	H2206B0671	Thread tension spring	2	1	1	
H51	HA310B0701	Thumb nut	2	1	1	
H52	HF206G7101	Mounting plate		1	1	
H53	HF208G8001	Thread guide		1	1	
H54	HF209G8001	Thread controller stud		1	1	
H55	HF210G8001	Tension release lever		1	1	
H56	HF211G8001	Thread guide	1	1	1	
H57	HE033B8001	Thread guide(lower)	1	1	1	
H58	HE032B8001	Screw	1	1	1	
H59	H3108B0692	Oil pad	1	1	1	
H60	HE929G8001	Thread take-up spring	1			
H61	HE930G7101	Stopper	1			
H62	HA300C2030	Screw	4	4	4	

I. SPECIAL PARTS FOR GC24698-5L、5R

---

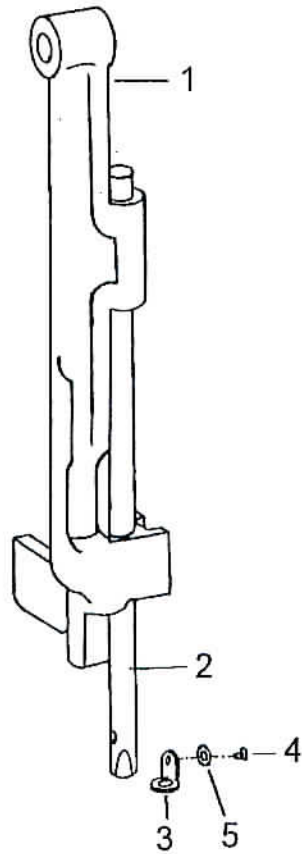

From the library of: Diamond Needle Corp



I. SPECIAL PARTS FOR GC24698-5L, 5R

Fig. Nos	Parts. Nos	Description	GC24698-5L	GC24698-5R	Notes
I01	HF204D8001	Needle bar guide bracket	1	1	
I02	HF205D8001	Needle bar	1	1	
I03	HF206D8001	Needle bar thread guide	1	1	
I04	H4915J8001	Set screw	1	1	
I05	H005001025	Flat washer	1	1	

J. SPECIAL PARTS FOR GC24698-6

specifications	Needle bar (C08)	Needle plate (E39)	Vibrating presser foot (C41)	Lifting presser foot (C25)	Feed dog (E35)	Bracket (E40)	Plate (E41)	Cover plate (E45)
1/4"	HE970D8001	HY12F48001	HE962D8001	HE954D8001	HY13E18001	HY13F28001	HY14F08001	HY14F88001
3/8"	HE971D8001	HY12F58001	HE963D8001	HE955D8001	HY13E28001	HY13F38001	HY14F18001	HY14F98001
1/2"	HE972D8001	HY12F68001	HE964D8001	HE956D8001	HY13E38001	HY13F48001	HY14F28001	HY15F08001
7/8"	HE973D8001	HY12F78001	HE965D8001	HE957D8001	HY13E48001	HY13F58001	HY14F38001	HY15F18001
3/4"	HE908D8001	HY11F78001	HE928D8001	HE919D8001	HY11E08001	HY11F48001	HY11F58001	HY12F28001
1"	HE974D8001	HY12F88001	HE966D8001	HE958D8001	HY13E58001	HY13F68001	HY14F48001	HY15F28001
1 1/4"	HE975D8001	HY12F98001	HE967D8001	HE959D8001	HY13E68001	HY13F78001	HY14F58001	HY15F38001
1 1/2"	HE976D8001	HY13F08001	HE968D8001	HE960D8001	HY13E78001	HY13F88001	HY14F68001	HY15F48001
1 3/4"	HE977D8001	HY13F18001	HE969D8001	HE961D8001	HY13E88001	HY13F98001	HY14F78001	HY15F58001

# K. ACCESSORIES

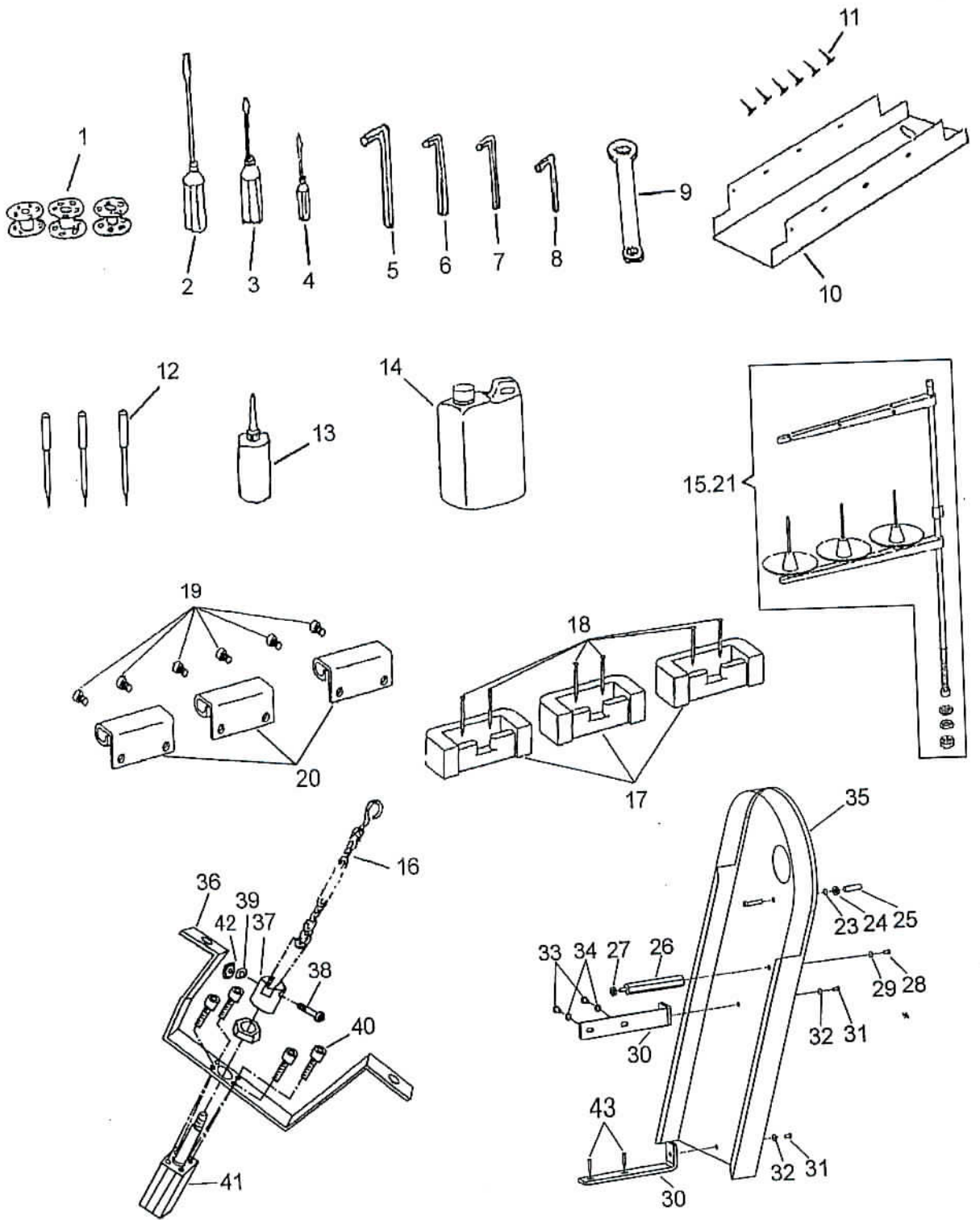

From the library of: Diamond Needle Corp



# K. ACCESSORIES

Fig. Nos	Parts. Nos	Description	GC24698-6	GC24698-5L	GC24698-5R	Notes
K01	HE933F7101	Bobbin	3	2	2	
K02	HA300J2070	Screw drive(large)	1	1	1	
K03	HA300J2200	Screw drive(middle)	1	1	1	
K04	HA300J2210	Screw drive(small)	1	1	1	
K05	HB01001040	Inner hexagonal wrench(4)	1	1	1	
K06	HB01001030	Inner hexagonal wrench(3)	1	1	1	
K07	HB01001025	Inner hexagonal wrench(2.5)	1	1	1	
K08	HB01001015	Inner hexagonal wrench(1.5)	1	1	1	
K09	HA300J2220	Spanner	1	1	1	
K10	HF404H8001	Oil plate	1	1	1	
K11	HJ02016250	Nail	10	10	10	
K12	HE909D8001	Needle	6	6	6	DY×3 #25
K13	H200400069	Oiler	1	1	1	
K14	HA300J2170	Oil	1	1	1	
K15	H3200L0120	Thread stand(double needle)	1			
K16	H3200L0120	Chain	1	1	1	
K17	HA307J0671	Vibration preventing rubber	3	3	3	
K18	HJ02016250	Nail	6	6	6	
K19	HE010M8001	Screw	6	6	6	
K20	HE009M8001	Hinge	3	3	3	
K21	H3200L0120	Thread stand		1	1	
K22	H410050200	Screw	1	1	1	
K23	H005008050	Spring washer	1	1	1	
K24	H003001050	Nut	1	1	1	
K25	HF427B8001	Casing pipe	1	1	1	
K26	HF419B8001	Supporting screw	1	1	1	
K27	H003001060	Nut	1	1	1	
K28	H410050060	Screw	1	1	1	
K29	H005008050	Spring washer	1	1	1	
K30	HF420B8001	Support plate	1	1	1	
K31	H410050060	Screw	1	1	1	
K32	H005008050	Spring washer	1	1	1	
K33	H410040150	Screw	2	2	2	
K34	H005008040	Spring washer	2	2	2	
K35	HF421B7101	Belt cover assembly	1	1	1	
K36	HF424B8001	Cylinder block	1	1	1	
K37	HF425B8001	Cylinder joint	1	1	1	
K38	HA712N0692	Triming solenoid pin	1	1	1	
K39	H007013040	Thackeray washer	2	2	2	
K40	H415060150	Screw	4	4	4	
K41	H0313L8001	Cylinder	1	1	1	SDA32×50-B
K42	H003002050	Nut	1	1	1	
K43	50200	lag wood screw	2	2	2	

**SHANGHAI HUIGONG NO.3 SEWING MACHINE FACTORY**

**ADD: 1418, Yishan Road, Shanghai, China**

**Zip Code: 201103**

**Overseas Business: TEL: 86-21-64853303 FAX: 86-21-64854304**

**E-mail: [highlead@online.sh.cn](mailto:highlead@online.sh.cn) <http://www.highlead.com.cn>**

The description covered in this manual is subject to change for improvement of the commodity without notice

2008.4. Printed